

Comlinear® CLC1003

Single, Dual, and Quad RRIO Amplifiers



FEATURES

- 1mV max input offset voltage
- 0.00005% THD at 1kHz
- 5.3nV/√Hz input voltage noise >10kHz
- -90dB/-85dB HD2/HD3 at 100kHz, $R_L=100\Omega$
- <-100dB HD2 and HD3 at 10kHz, $R_L=1k\Omega$
- Rail-to-Rail input and output
- 55MHz unity gain bandwidth
- 12V/μs slew rate
- +80mA, -55mA output current
- -40°C to +125°C operating temperature
- Fully specified at 3V and ±5V supplies
- CLC1003: Pb-free SOT23-5. SOIC-8
- Future option CLC2003: Dual
- Future option CLC4003: Quad

APPLICATIONS

- Active filters
- Sensor interface
- High-speed transducer amp
- Medical instrumentation
- Probe equipment
- Test equipment

General Description

The Comlinear CLC1003(single), CLC2003(dual), and CLC4003 (quad) are high-performance, voltage feedback amplifiers with near precision performance, low input voltage noise, and ultra low distortion. The CLC1003 family of amplifiers offers 1mV maximum input offset voltage, 5.3nV/√Hz input voltage noise, and 0.00005% THD at 1kHz. These amplifiers also provide 55MHz gain bandwidth product and 12V/μs slew rate making them well suited for applications requiring precision DC performance and high AC performance. These Comlinear high-performance amplifiers also offer a rail-to-rail input and output, simplifying single supply designs and offering larger dynamic range possibilities. The inputs extend beyond the rails by 300mV.

The Comlinear CLC1003 family of amplifiers are designed to operate from 2.5V to 12V supplies. These Comlinear amplifiers operate over the extended temperature range of -55°C to +125°.

Typical Application - Single Supply Photodiode Amplifier

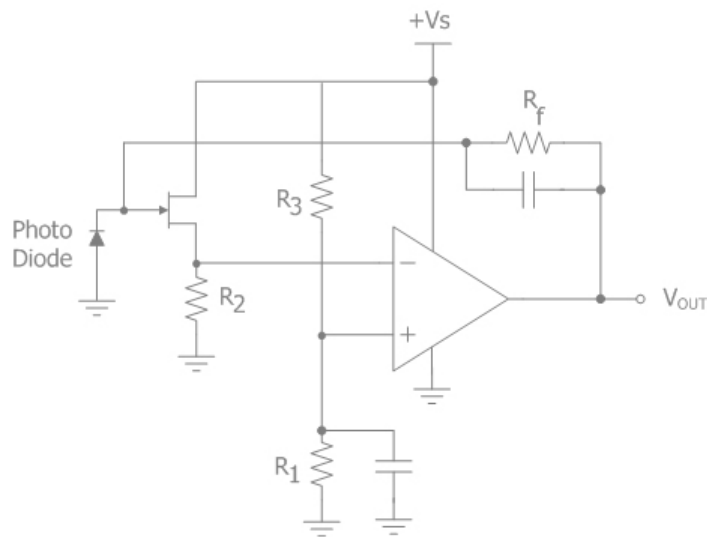

Ordering Information

Part Number	Package	Pb-Free	RoHS Compliant	Operating Temperature Range	Packaging Method
CLC1003IST5X	SOT23-5	Yes	Yes	-40°C to +85°C	Reel
CLC1003ISO8X*	SOIC-8	Yes	Yes	-40°C to +85°C	Reel
CLC1003ISO8*	SOIC-8	Yes	Yes	-40°C to +85°C	Rail
CLC1003AST5X	SOT23-5	Yes	Yes	-40°C to +125°C	Reel
CLC1003ASO8X*	SOIC-8	Yes	Yes	-40°C to +125°C	Reel
CLC1003ASO8*	SOIC-8	Yes	Yes	-40°C to +125°C	Rail

*Preliminary Product Information
Moisture sensitivity level for all parts is MSL-1.

Electrical Characteristics

T_A = 25°C, V_S = ±5V, R_f = 1kΩ, R_L = 1kΩ to GND, G = 2; unless otherwise noted.

Parameter	Conditions	Min	Typ	Max	Units
Frequency Domain Response					
-3dB Gain Bandwidth Product	G = 10, V _{OUT} = 0.05V _{pp}		35		MHz
Unity Gain Bandwidth	V _{OUT} = 0.05V _{pp} , R _f = 0		55		MHz
-3dB Bandwidth	V _{OUT} = 0.05V _{pp}		25		MHz
Large Signal Bandwidth	V _{OUT} = 2V _{pp}		3.6		MHz
Time Domain Response					
Rise and Fall Time	V _{OUT} = 2V step; (10% to 90%)		125		ns
Settling Time to 0.1%	V _{OUT} = 2V step		80		ns
Overshoot	V _{OUT} = 2V step		0.3		%
Slew Rate	4V step		12		V/μs
Distortion/Noise Response					
2nd Harmonic Distortion	2V _{pp} , 10kHz, R _L = 1kΩ		-125		dBc
	2V _{pp} , 100kHz, R _L = 100Ω		-90		dBc
3rd Harmonic Distortion	2V _{pp} , 10kHz, R _L = 1kΩ		-127		dBc
	2V _{pp} , 100kHz, R _L = 100Ω		-85		dBc
Total Harmonic Distortion	1V _{pp} , 1kHz, G=1, R _L = 2kΩ		0.00005		%
Input Voltage Noise	> 10kHz		5.3		nV/√Hz
Input Voltage Noise	> 100kHz		3.5		nV/√Hz
DC Performance					
Input Offset Voltage ⁽¹⁾		-1	0.050	1	mV
Average Drift			1.3		μV/°C
Input Bias Current ⁽¹⁾		-2.6	-0.30	2.6	μA
Average Drift			0.85		nA/°C
Input Offset Current ⁽¹⁾			0.2	0.7	μA
Power Supply Rejection Ratio ⁽¹⁾	DC	82	100		dB
Open-Loop Gain ⁽¹⁾	V _{OUT} = V _S / 2	95	115		dB
Supply Current ⁽¹⁾	per channel		2.2	2.75	mA
Input Characteristics					
Input Resistance	Non-inverting, G = 1		30		MΩ
Input Capacitance			1		pF
Common Mode Input Range			±5.5		V
Common Mode Rejection Ratio ⁽¹⁾	DC, V _{cm} = -3V to 3V	70	95		dB
Output Characteristics					
Output Voltage Swing	R _L = 150Ω		-4.826 to 4.534		V
	R _L = 1kΩ ⁽¹⁾	-4.7	-4.93 to 4.85	4.7	V
Output Current			+80, -55		mA
Short-Circuit Output Current	V _{OUT} = V _S / 2		+115, -90		mA

Notes:

1. 100% tested at 25°C. Refer to the data sheet for complete product specifications

For additional information regarding our products, please visit CADEKA at: cadeka.com

CADEKA Headquarters Loveland, Colorado
 T: 970.663.5452
 T: 877.663.5452 (toll free)

CADEKA, the CADEKA logo design, and Comlinear and the Comlinear logo design, are trademarks or registered trademarks of CADEKA Microcircuit LLC. All other brand and product names may be trademarks of their respective companies.
 Copyright ©2008 by CADEKA Microcircuit LLC. All rights reserved.

Available Packages

CLC1003 SOT23-5

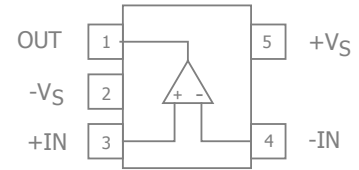

CLC2003 SOIC-8

(future option)

