

Comlinear™ CLC1603, CLC3603

Single and Triple, 1.1mA, 200MHz Amplifiers

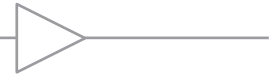

FEATURES

- 0.1dB gain flatness to 30MHz
- 0.02%/0.1° differential gain/phase
- 200MHz -3dB bandwidth at G = 2
- 140MHz large signal bandwidth
- 450V/μs slew rate
- 1.1mA supply current (enabled)
- 0.35mA supply current (disabled)
- 100mA output current
- Fully specified at 5V and ±5V supplies
- CLC1603: Lead-free SC70-6, SOT23-6, SOIC-8
- CLC3603: Lead-free SOIC-14, TSSOP-16

APPLICATIONS

- RGB video line drivers
- Portable Video
- Line drivers
- Set top box
- Active filters
- Cable drivers
- Imaging applicaitons
- Radar/communication receivers

General Description

The *Comlinear* CLC1603 (single) and CLC3603 (triple) are high-performance, current feedback amplifiers that provide 200MHz gain of 2 bandwidth, ±0.1dB gain flatness to 30MHz, and 450V/μs slew rate while consuming only 1.1mA of supply current. This high performance exceeds the requirements of NTSC/PAL/HDTV video applications. These *Comlinear* high-performance amplifiers also provide ample output current to drive multiple video loads.

The *Comlinear* CLC1603 and CLC3603 are designed to operate from ±5V or +5V supplies. They offer an enable/disable feature to save power. While disabled, the outputs are in a high-impedance state to allow for multiplexing applications. The combination of high-speed, low-power, and excellent video performance make these amplifiers well suited for use in many general purpose, high-speed applications including set top boxes, high-definition video, active filters, and cable driving applications.

Typical Application - TBD

Ordering Information

Part Number	Package	Pb-Free	Operating Temperature Range	Packaging Method
CLC1603ISC6X*	SC70-6	Yes	-40°C to +85°C	Reel
CLC1603IST6X*	SOT23-6	Yes	-40°C to +85°C	Reel
CLC1603IST6*	SOT23-6	Yes	-40°C to +85°C	Rail
CLC1603ISO8X*	SOIC-8	Yes	-40°C to +85°C	Reel
CLC1603ISO8*	SOIC-8	Yes	-40°C to +85°C	Rail
CLC3603ISO14X*	SOIC-14	Yes	-40°C to +85°C	Reel
CLC3603ISO14*	SOIC-14	Yes	-40°C to +85°C	Rail
CLC3603ITP16X*	TSSOP-16	Yes	-40°C to +85°C	Reel
CLC3603ITP16*	TSSOP-16	Yes	-40°C to +85°C	Rail

*Preliminary Product Information

Moisture sensitivity level for all parts is MSL-1.



SOT23/SC70 Pin Configuration

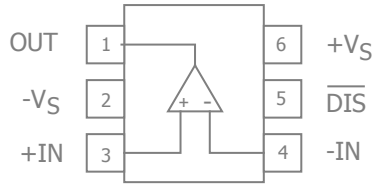

SOT23/SC70 Pin Assignments

Pin No.	Pin Name	Description
1	OUT	Output
2	-V _S	Negative supply
3	+IN	Positive input
4	-IN	Negative input
5	$\overline{\text{DIS}}$	Disable. Enabled if pin is left floating or pulled above V _{ON} , disabled if pin is grounded or pulled below V _{OFF} .
6	+V _S	Positive supply

SOIC Pin Configuration

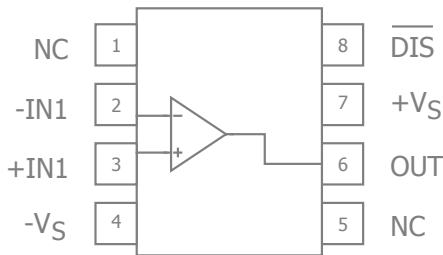

SOIC Pin Assignments

Pin No.	Pin Name	Description
1	NC	No connect
2	-IN1	Negative input, channel 1
3	+IN1	Positive input, channel 1
4	-V _S	Negative supply
5	NC	No connect
6	OUT	Output
7	+V _S	Positive supply
8	$\overline{\text{DIS}}$	Disable. Enabled if pin is left floating or pulled above V _{ON} , disabled if pin is grounded or pulled below V _{OFF} .

Disable Pin Truth Table

Pin	High*	Low
$\overline{\text{DIS}}$	Enabled	Disabled

*Default Open State



SOIC Pin Configuration

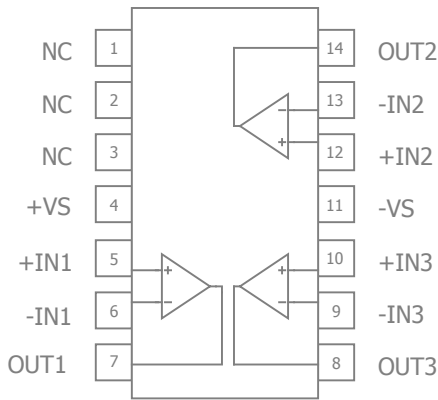

CLC1603 SOIC Pin Assignments

Pin No.	Pin Name	Description
1	NC	No Connect
2	NC	No Connect
3	NC	No Connect
4	+VS	Positive supply
5	+IN1	Positive input, channel 1
6	-IN1	Negative input, channel 1
7	OUT1	Output, channel 1
8	OUT3	Output, channel 3
9	-IN3	Negative input, channel 3
10	+IN3	Positive input, channel 3
11	-VS	Negative supply
12	+IN2	Positive input, channel 2
13	-IN2	Negative input, channel 2
14	OUT2	Output, channel 2

TSSOP Pin Configuration

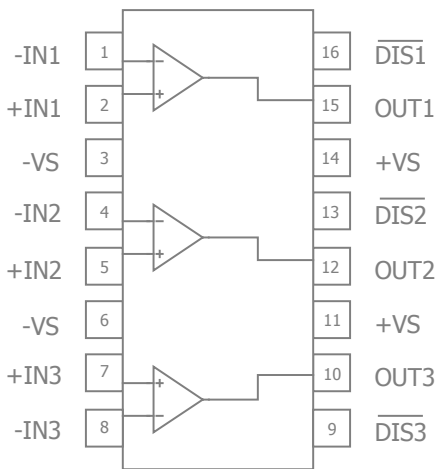

CLC3603 TSSOP Pin Configuration

Pin No.	Pin Name	Description
1	-IN1	Negative input, channel 1
2	+IN1	Positive input, channel 1
3	-VS	Negative supply
4	-IN2	Negative input, channel 2
5	+IN2	Positive input, channel 2
6	-VS	Negative supply
7	+IN3	Positive input, channel 3
8	-IN3	Negative input, channel 3
9	DIS3	Disable pin for channel 3. Enabled if pin is left floating or pulled above V _{ON} , disabled if pin is grounded or pulled below V _{OFF} .
10	OUT3	Output, channel 3
11	+VS	Positive supply
12	OUT2	Output, channel 2
13	DIS2	Disable pin for channel 2. Enabled if pin is left floating or pulled above V _{ON} , disabled if pin is grounded or pulled below V _{OFF} .
14	+VS	Positive supply
15	OUT1	Output, channel 1
16	DIS1	Disable pin for channel 1. Enabled if pin is left floating or pulled above V _{ON} , disabled if pin is grounded or pulled below V _{OFF} .



Absolute Maximum Ratings

The "Absolute Maximum Ratings" are those values beyond which the safety of the device cannot be guaranteed. The device should not be operated at these limits. The parametric values defined in the Electrical Characteristics tables are not guaranteed at the absolute maximum ratings. The "Recommended Operating Conditions" table defines the conditions for actual device operation.

Parameter	Min	Max	Unit
Supply Voltage	0	14	V
Input Voltage Range	$-V_S - 0.5V$	$+V_S + 0.5V$	V

Reliability Information

Parameter	Min	Typ	Max	Unit
Junction Temperature			150	°C
Storage Temperature Range	-65		150	°C
Lead Temperature (Soldering, 10s)			300	°C
Package Thermal Resistance				
6-Lead SC70		TBD		°C/W
6-Lead SOT23		TBD		°C/W
8-Lead SOIC		TBD		°C/W
14-Lead SOIC		TBD		°C/W
16-Lead TSSOP		TBD		°C/W

Notes:

Package thermal resistance (θ_{JA}), JEDEC standard, multi-layer test boards, still air.

ESD Protection

Product	SC70-6	SOT23-6	SOIC-8	SOIC-14	TSSOP-16
Human Body Model (HBM)	2kV	2kV	2kV	2kV	2kV
Charged Device Model (CDM)	1kV	1kV	1kV	1kV	1kV

Notes:

0.8kV between the input pins (+IN and -IN), all other pins are 2kV.

Recommended Operating Conditions

Parameter	Min	Typ	Max	Unit
Operating Temperature Range	-40		+85	°C
Supply Voltage Range	4.5		12	V

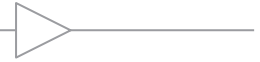

Electrical Characteristics at +5V

$T_A = 25^\circ\text{C}$, $V_S = +5\text{V}$, $R_f = R_g = 1.2\text{k}\Omega$, $R_L = 100\Omega$ to $V_S/2$, $G = 2$; unless otherwise noted.

Symbol	Parameter	Conditions	Min	Typ	Max	Units
Frequency Domain Response						
UGBW	Unity Gain Bandwidth	$G = +1$, $V_{OUT} = 0.2V_{pp}$, $R_f = xxx\Omega$		TBD		MHz
BW _{SS}	-3dB Bandwidth	$G = +2$, $V_{OUT} = 0.2V_{pp}$		180		MHz
BW _{LS}	Large Signal Bandwidth	$G = +2$, $V_{OUT} = 1V_{pp}$		130		MHz
BW _{0.1dBSS}	0.1dB Gain Flatness	$G = +2$, $V_{OUT} = 0.2V_{pp}$		15		MHz
Time Domain Response						
t_R , t_F	Rise and Fall Time	$V_{OUT} = 1\text{V}$ step; (10% to 90%)		8		ns
t_S	Settling Time to 0.1%	$V_{OUT} = 1\text{V}$ step		18		ns
	Settling Time to 0.01%	$V_{OUT} = 1\text{V}$ step		40		ns
OS	Overshoot	$V_{OUT} = 0.2\text{V}$ step		TBD		%
SR	Slew Rate	2V step		350		V/ μs
Distortion/Noise Response						
HD2	2nd Harmonic Distortion	$V_{OUT} = 1V_{pp}$, 5MHz		-67		dBc
HD3	3rd Harmonic Distortion	$V_{OUT} = 1V_{pp}$, 5MHz		-57		dBc
THD	Total Harmonic Distortion	$V_{OUT} = 1V_{pp}$, 5MHz		55		dB
D _G	Differential Gain	NTSC (3.58MHz), DC-coupled, $R_L = 150\Omega$		0.02		%
D _P	Differential Phase	NTSC (3.58MHz), DC-coupled, $R_L = 150\Omega$		0.1		°
IP3	Third Order Intercept	$V_{OUT} = 0.5V_{pp}$, 10MHz		35		dBm
SFDR	Spurious Free Dynamic Range	$V_{OUT} = 1V_{pp}$, 5MHz		58		dBc
e_n	Input Voltage Noise	> 1MHz		4		nV/ $\sqrt{\text{Hz}}$
i_n	Input Current Noise	> 1MHz, Inverting		15		pA/ $\sqrt{\text{Hz}}$
		> 1MHz, Non-Inverting		15		pA/ $\sqrt{\text{Hz}}$
X _{TALK}	Crosstalk	Channel-to-channel 5MHz		60		dB
DC Performance						
V _{IO}	Input Offset Voltage			0.5		mV
dV _{IO}	Average Drift			6		$\mu\text{V}/^\circ\text{C}$
I _{bn}	Input Bias Current - Non-Inverting			2		μA
dI _{bn}	Average Drift			40		nA/ $^\circ\text{C}$
I _{bi}	Input Bias Current - Inverting			0.4		μA
dI _{bi}	Average Drift			10		nA/ $^\circ\text{C}$
PSRR	Power Supply Rejection Ratio	DC		60		dB
A _{OL}	Open-Loop Transimpedance Gain	$V_{OUT} = V_S / 2$		TBD		k Ω
I _S	Supply Current	per channel		0.9		mA
Disable Characteristics - CLC3603 in TSSOP-16 only						
T _{ON}	Turn On Time			900		ns
T _{OFF}	Turn Off Time			500		ns
OFF _{IOS}	Off Isolation	5MHz		TBD		dB
OFF _{COU}	Off Output Capacitance			TBD		pF
OFF _{ROU}	Off Output Resistance			TBD		k Ω
V _{OFF}	Power Down Input Voltage	$\overline{\text{DIS}}$ pin, disabled if pin is grounded or pulled below V _{OFF}			1.5	V
V _{ON}	Enable Input Voltage	$\overline{\text{DIS}}$ pin, enabled if pin is left open or pulled above V _{ON}	3.5			V
I _{SD}	Disable Supply Current	$\overline{\text{DIS}}$ pin is grounded		0.15	0.35	mA



Electrical Characteristics at +5V continued

$T_A = 25^\circ\text{C}$, $V_S = +5\text{V}$, $R_f = R_g = 1.2\text{k}\Omega$, $R_L = 100\Omega$ to $V_S/2$, $G = 2$; unless otherwise noted.

Symbol	Parameter	Conditions	Min	Typ	Max	Units
Input Characteristics						
R_{IN}	Input Resistance	Non-inverting		4		$\text{M}\Omega$
		Inverting		350		Ω
C_{IN}	Input Capacitance			1.0		pF
CMIR	Common Mode Input Range			1.5 to 3.5		V
CMRR	Common Mode Rejection Ratio	DC		55		dB
Output Characteristics						
R_O	Output Resistance	Closed Loop, DC		0.02		Ω
V_{OUT}	Output Voltage Swing	$R_L = 150\Omega$		1.4 to 3.6		V
		$R_L = 1\text{k}\Omega$		TBD		V
I_{OUT}	Output Current			± 80		mA
I_{SC}	Short-Circuit Output Current	$V_{OUT} = V_S / 2$		TBD		mA

Notes:

- 100% tested at 25°C



Electrical Characteristics at $\pm 5V$

$T_A = 25^\circ C$, $V_S = \pm 5V$, $R_f = R_g = 1.2k\Omega$, $R_L = 100\Omega$ to GND, $G = 2$; unless otherwise noted.

Symbol	Parameter	Conditions	Min	Typ	Max	Units
Frequency Domain Response						
UGBW	Unity Gain Bandwidth	$G = +1$, $V_{OUT} = 0.2V_{pp}$, $R_f = xxx\Omega$		TBD		MHz
BW _{SS}	-3dB Bandwidth	$G = +2$, $V_{OUT} = 0.2V_{pp}$		200		MHz
BW _{LS}	Large Signal Bandwidth	$G = +2$, $V_{OUT} = 2V_{pp}$		140		MHz
BW _{0.1dBSS}	0.1dB Gain Flatness	$G = +2$, $V_{OUT} = 0.2V_{pp}$		30		MHz
Time Domain Response						
t_R , t_F	Rise and Fall Time	$V_{OUT} = 1V$ step; (10% to 90%)		1.5		ns
t_S	Settling Time to 0.1%	$V_{OUT} = 1V$ step		18		ns
	Settling Time to 0.01%	$V_{OUT} = 1V$ step		35		ns
OS	Overshoot	$V_{OUT} = 0.2V$ step		TBD		%
SR	Slew Rate	2V step		450		V/ μ s
Distortion/Noise Response						
HD2	2nd Harmonic Distortion	$V_{OUT} = 1V_{pp}$, 5MHz		-67		dBc
HD3	3rd Harmonic Distortion	$V_{OUT} = 1V_{pp}$, 5MHz		-57		dBc
THD	Total Harmonic Distortion	$V_{OUT} = 1V_{pp}$, 5MHz		55		dB
D _G	Differential Gain	NTSC (3.58MHz), DC-coupled, $R_L = 150\Omega$		0.02		%
D _P	Differential Phase	NTSC (3.58MHz), DC-coupled, $R_L = 150\Omega$		0.1		°
IP3	Third Order Intercept	$V_{OUT} = 0.5V_{pp}$, 10MHz		35		dBm
SFDR	Spurious Free Dynamic Range	$V_{OUT} = 1V_{pp}$, 5MHz		58		dBc
e_n	Input Voltage Noise	> 1MHz		4		nV/ \sqrt{Hz}
i_n	Input Current Noise	> 1MHz, Inverting		15		pA/ \sqrt{Hz}
		> 1MHz, Non-Inverting		15		pA/ \sqrt{Hz}
X _{TALK}	Crosstalk	Channel-to-channel 5MHz		60		dB
DC Performance						
V _{IO}	Input Offset Voltage ⁽¹⁾		-4	0.7	4	mV
dV _{IO}	Average Drift			6		μ V/ $^\circ C$
I _{bn}	Input Bias Current - Non-Inverting ⁽¹⁾		-5	2	5	μ A
dI _{bn}	Average Drift			40		nA/ $^\circ C$
I _{bi}	Input Bias Current - Inverting ⁽¹⁾		-5	6	5	μ A
dI _{bi}	Average Drift			10		nA/ $^\circ C$
PSRR	Power Supply Rejection Ratio ⁽¹⁾	DC	50	60		dB
A _{OL}	Open-Loop Transimpedance Gain	$V_{OUT} = V_S / 2$		TBD		k Ω
I _S	Supply Current ⁽¹⁾	per channel		1.1	2.0	mA
Disable Characteristics - CLC3603 only						
T _{ON}	Turn On Time			900		ns
T _{OFF}	Turn Off Time			500		ns
OFF _{IOS}	Off Isolation	5MHz		TBD		dB
OFF _{COU}	Off Output Capacitance			TBD		pF
OFF _{ROU}	Off Output Resistance			TBD		k Ω
V _{OFF}	Power Down Input Voltage	\overline{DIS} pin, disabled if pin is grounded or pulled below V _{OFF}			-3.5	V
V _{ON}	Enable Input Voltage	\overline{DIS} pin, enabled if pin is left open or pulled above V _{ON}	3.5			V
I _{SD}	Disable Supply Current ⁽¹⁾	\overline{DIS} pin is grounded		0.35	0.5	mA



Electrical Characteristics at $\pm 5V$ continued

$T_A = 25^\circ C$, $V_S = \pm 5V$, $R_f = R_g = 1.2k\Omega$, $R_L = 100\Omega$ to GND, $G = 2$; unless otherwise noted.

Symbol	Parameter	Conditions	Min	Typ	Max	Units
Input Characteristics						
R_{IN}	Input Resistance	Non-inverting		4		$M\Omega$
		Inverting		350		Ω
C_{IN}	Input Capacitance			1.0		pF
CMIR	Common Mode Input Range			± 4.0		V
CMRR	Common Mode Rejection Ratio ⁽¹⁾	DC	50	55		dB
Output Characteristics						
R_O	Output Resistance	Closed Loop, DC		0.1		Ω
V_{OUT}	Output Voltage Swing	$R_L = 150\Omega$ ⁽¹⁾		± 3.5		V
		$R_L = 1k\Omega$		TBD		V
I_{OUT}	Output Current			± 100		mA
I_{SC}	Short-Circuit Output Current	$V_{OUT} = V_S / 2$		TBD		mA

Notes:

1. 100% tested at $25^\circ C$



Mechanical Dimensions

SOT23-6 Package

SOT23-6

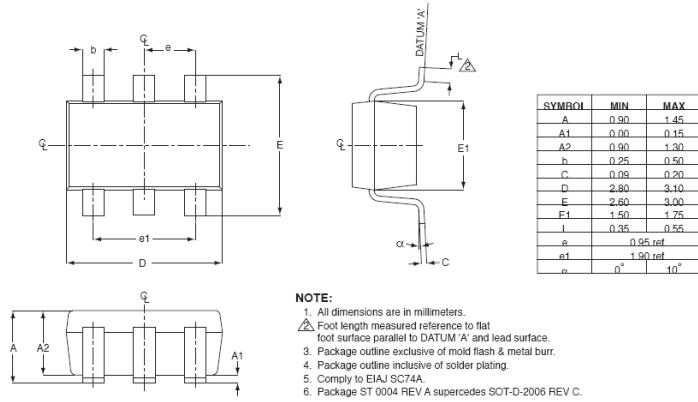

SC70-6



Mechanical Dimensions

SOIC-8 Package

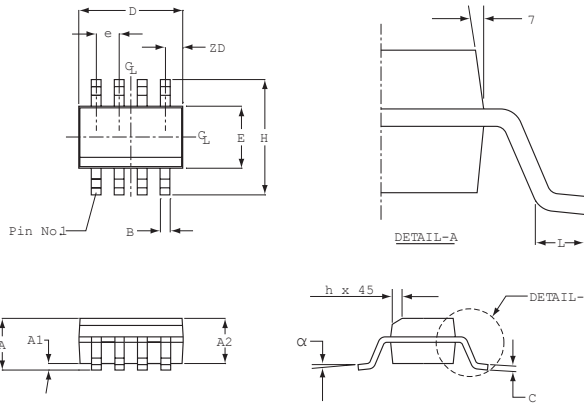

SOIC-8		
SYMBOL	MIN	MAX
A1	0.20	0.25
B	0.36	0.46
C	0.20	0.25
D	4.20	4.98
E	3.81	3.99
e	1.27 BSC	
H	5.20	6.20
h	0.25	0.50
L	0.41	1.27
A	1.52	1.72
ZD	0.50 ref	
A2	1.37	1.57

- NOTE:
1. All dimensions are in millimeters.
 2. Lead coplanarity should be 0 to 0.1mm (.004" max).
 3. Package surface finishing:
 - (1) Top: matte (charmilles #18-30).
 - (2) All sides: matte (charmilles #18-30).
 - (3) Bottom: smooth or matte (charmilles #18-30).
 4. All dimensions excluding mold flashes and end flash from the package body shall not exceed 0.15mm (.006 per side (d)).

SOIC-14 Package

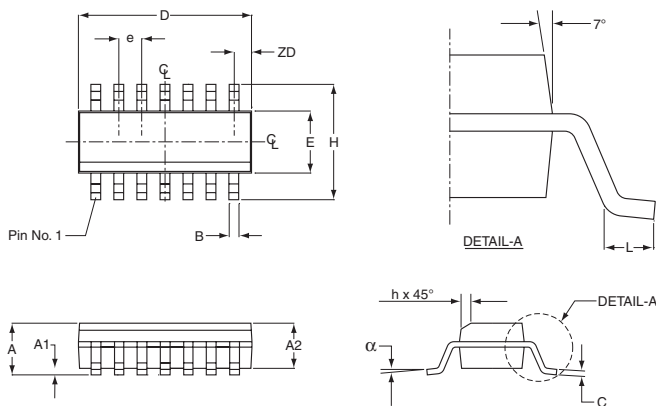

SOIC-14		
SYMBOL	MIN	MAX
A1	.0040	.0098
B	.014	.018
C	.0075	.0098
D	.337	.344
E	.150	.157
e	.050 BSC	
H	.2284	.2440
h	.0099	.0196
L	.016	.050
A	.060	.068
ZD	0° ref	
A2	.054	.062

- NOTE:
1. All dimensions are in inches.
 2. Lead coplanarity should be 0 to 0.10mm (.004" max).
 3. Package surface finishing:
 - (1) Top: matte (charmilles #18-30).
 - (2) All sides: matte (charmilles #18-30).
 - (3) Bottom: smooth or matte (charmilles #18-30).
 4. All dimensions excluding mold flashes and end flash from the package body shall not exceed 0.152mm (.006 per side (d)).



Mechanical Dimensions

TSSOP-16

For additional information regarding our products, please visit CADEKA at: cadeka.com

CADEKA Headquarters Loveland, Colorado

T: 970.663.5452

T: 877.663.5415 (toll free)

CADEKA, the CADEKA logo design, and Comlinear and the Comlinear logo design, are trademarks or registered trademarks of CADEKA Microcircuits LLC. All other brand and product names may be trademarks of their respective companies.

CADEKA reserves the right to make changes to any products and services herein at any time without notice. CADEKA does not assume any responsibility or liability arising out of the application or use of any product or service described herein, except as expressly agreed to in writing by CADEKA; nor does the purchase, lease, or use of a product or service from CADEKA convey a license under any patent rights, copyrights, trademark rights, or any other of the intellectual property rights of CADEKA or of third parties.

Copyright ©2007 by CADEKA Microcircuits LLC. All rights reserved.