

**General Description**

To aid in the evaluation of the KH103 operational amplifier, Cadeka Microcircuits has created evaluation PC boards: P/N 730005 for inverting gain applications, and P/N 730006 for non-inverting gain applications.

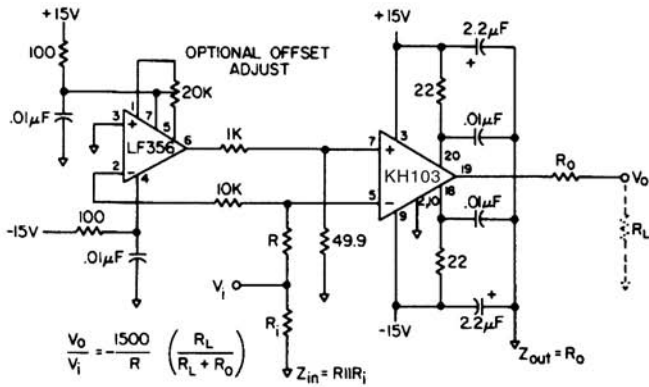

Figure 1: Inverting circuit with offset adjust circuitry

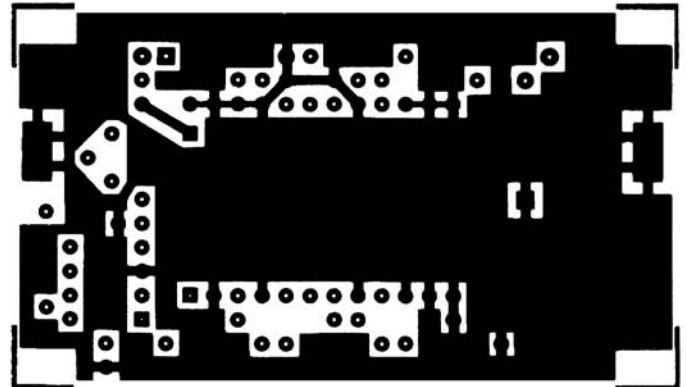

Figure 3: Circuit side (bottom) as viewed from component side, inverting

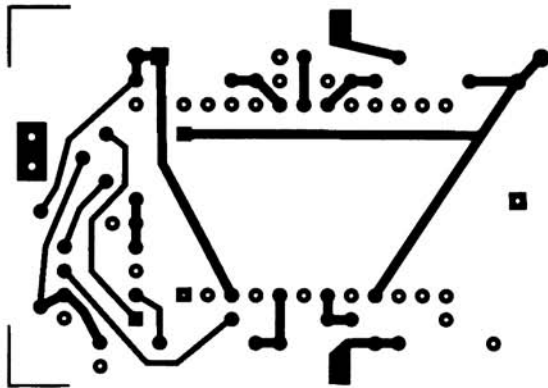

Figure 2: Component side (top), inverting

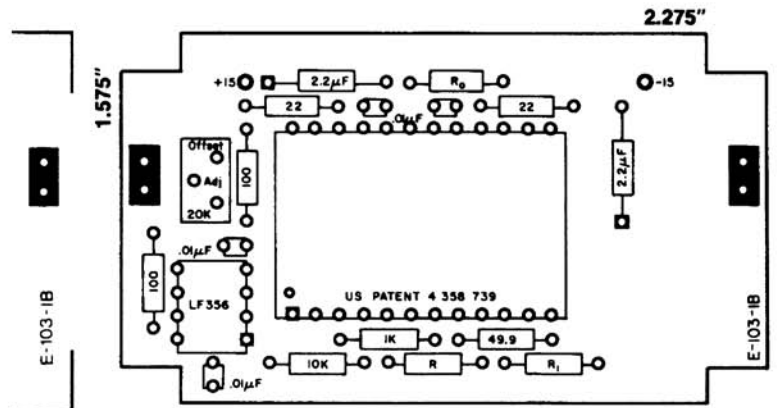

Figure 4: Component placement guide, inverting

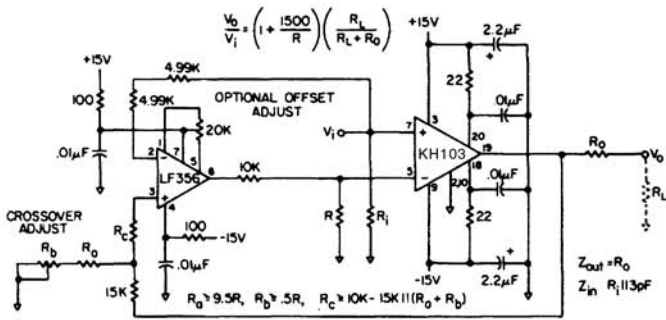

Figure 5: Non-inverting circuit with offset adjust circuitry

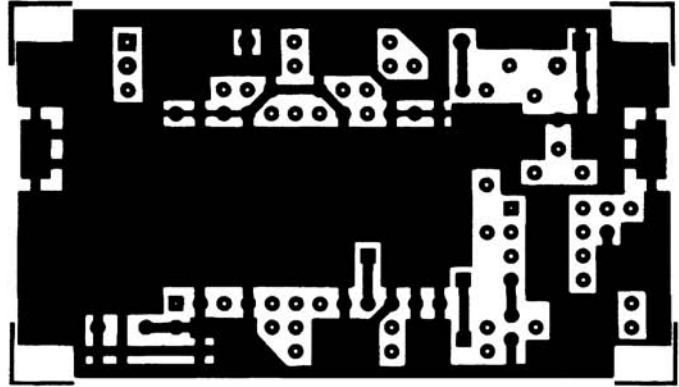

Figure 7: Circuit side (bottom) as viewed from component side, non-inverting

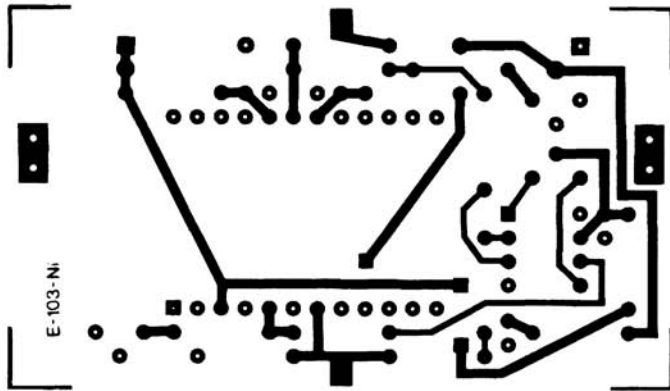

Figure 6: Component side (top), non-inverting

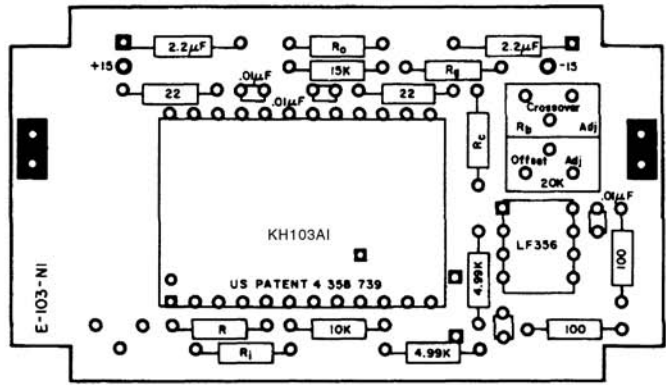

Figure 8: Component placement guide, non-inverting