

TMC1175A

Video A/D Converter

8 bit, 40 Mps

Features

- 8-Bit resolution
- 40 Mps conversion rate
- Low power: 100mW at 20 Mps
- Integral track/hold
- Integral and differential linearity error 0.5 LSB
- Single or dual +5 Volt supplies
- Differential phase 0.5 degree
- Differential gain 1.5%
- Three-state TTL/CMOS-compatible outputs
- Low cost

Applications

- Video digitizing
- VGA and CCD digitizing
- LCD projection panels
- Image scanners
- Personal computer video boards
- Multimedia systems
- Low cost, high speed data conversion

Description

The TMC1175A analog-to-digital (A/D) converter employs a two-step flash architecture to convert analog signals into 8-bit digital words at sample rates of up to 40 Mps (Megasamples per second). An integral Track/Hold circuit delivers excellent performance on signals with full-scale frequency components up to 12 MHz. Innovative architecture and submicron CMOS technology limit typical power dissipation to 100 mW.

Power may be derived from either single or dual +5V supplies. Internal voltage reference resistors allow self-bias operation. Input capacitance is very low, simplifying or eliminating input driving amplifiers. All digital three-state outputs are TTL- and CMOS-compatible.

The TMC1175A is available in 24-lead plastic SOIC, and 28-lead J-lead PLCC packages. Performance specifications are guaranteed from -20°C to 75°C.

Block Diagram

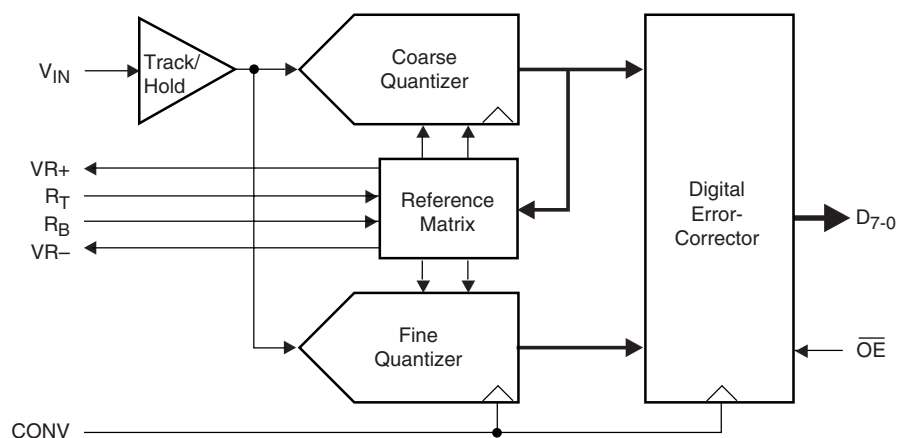

Functional Description

The TMC1175A 8-bit A/D converter uses a two-step architecture to perform analog-to-digital conversion at rates up to 40 Msps. The input signal is held in an integral track/hold stage during the conversion process. Operation is pipelined, with one input sample taken and one output word provided for each CONVert cycle.

The first step in the conversion process is a coarse 4-bit quantization. This determines the range of the subsequent fine 4-bit quantization step. To eliminate spurious codes, the fine 4-bit A/D quantizer output is gray-coded and converted to binary before it is combined with the coarse result to form a complete 8-bit result.

Analog Input and Voltage References

The TMC1175A converts analog signals in the range R_B to R_T into digital data. Input signals outside that range produce “saturated” 00h or FFh output codes. The device will not be damaged by signals within the range AGND to V_{DDA} .

Input voltage range is very flexible and extends from the +5 Volt power supply to ground. Performance is specified over the optimum 2 volt input range: 0.6V to 2.6V. However, the part will function with a full-scale range from 1.0V to 5.0V. A reduced input range may simplify analog signal conditioning circuitry, at the expense of additional noise sensitivity and reduced differential linearity. Increasing the range can improve differential linearity, but imposes a greater burden on the input signal conditioning circuitry.

In many applications, external voltage reference sources are connected to the R_T and R_B pins. R_B can be grounded. Gain and offset errors are directly related to the accuracy and stability of the applied reference voltages.

Two reference pull-up and pull-down resistors connected to $VR+$ and $VR-$ are provided internally for operation without external voltage reference circuitry (Figure 1). The reference voltages applied to R_T and R_B may be generated by connecting $VR+$ to R_T and $VR-$ to R_B . The power supply voltage is divided by the on-chip resistors to bias the R_T and R_B points. This sets-up the converter for operation in its nominal range from 0.6V to 2.6V.

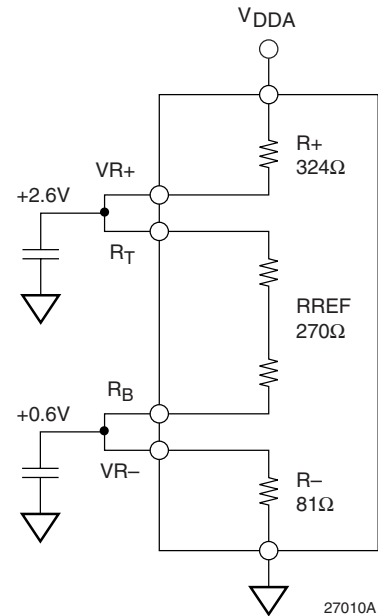

Figure 1. Reference Resistors

With V_{DDA} at 5.0V, connecting $VR+$ to R_T and grounding R_B will provide an input range from 0.0V to 2.27V, while connecting R_T to V_{DDA} and R_B to $VR-$ produces a full scale range of 3.85V referenced to V_{DDA} . External resistors may also be employed to provide arbitrary reference voltages, but they will not match the temperature coefficient of the on-chip resistors as well as $R+$ and $R-$, and will cause the converter transfer function to vary with temperature.

With this implementation, errors in the power supply voltage end up on the conversion data output.

Because a two-step conversion process is employed, it is important that the references remain stable during the ENTIRE conversion process (two clock cycles). The reference voltage can then be changed, but any conversion in progress during a reference change is invalid.

Table 1. Output Coding

Input Voltage	Output
$R_T + 1 \text{ LSB}$	FF
R_T	FF
$R_T - 1 \text{ LSB}$	FE
...	...
$R_B + 128 \text{ LSB}$	80
$R_B + 127 \text{ LSB}$	7F
...	...
$R_B + 1 \text{ LSB}$	01
R_B	00
$R_B - 1 \text{ LSB}$	00

Note:

1. $\text{LSB} = (R_T - R_B) / 255$

Digital Inputs and Outputs

Sampling of the applied input signal takes place on the **falling** edge of the CONV signal (Figure 2). The output word is delayed by 2 1/2 CONV cycles. It is then available after the **rising** edge of CONV. The previous data on the output

remain valid for t_{HO} (Output Hold Time), satisfying any hold time requirement of the receiving circuit. The new data become valid t_{DO} (Output Delay Time) after this rising edge of CONV.

The outputs of the TMC1175A are CMOS- and TTL-compatible, and are capable of driving four low-power Schottky TTL (54/74LS) loads. An Output Enable control, \overline{OE} , places the outputs in a high-impedance state when HIGH. The outputs are enabled when \overline{OE} is LOW.

Power and Ground

To minimize noise injection into the analog section, V_{DDA} may be connected to a separate regulated +5 volt supply. V_{DDD} may be connected to a digital supply. Power up sequence is immaterial. Latch-up will not occur.

AGND and DGND pins should be connected to a common ground plane. For optimum performance treat analog and digital PWB traces as transmission lines. Route analog connections cleanly to the TMC1175A. Segregate digital connections and if necessary terminate clocks to eliminate ringing. Prevent digital return currents from flowing across analog input sections of the TMC1175A.

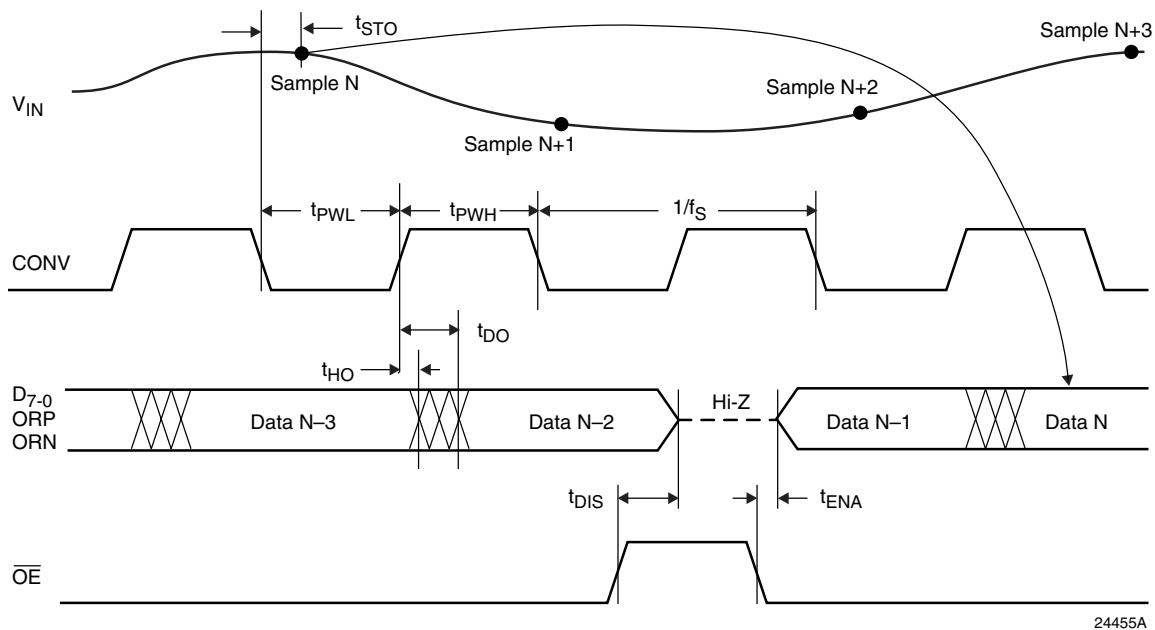
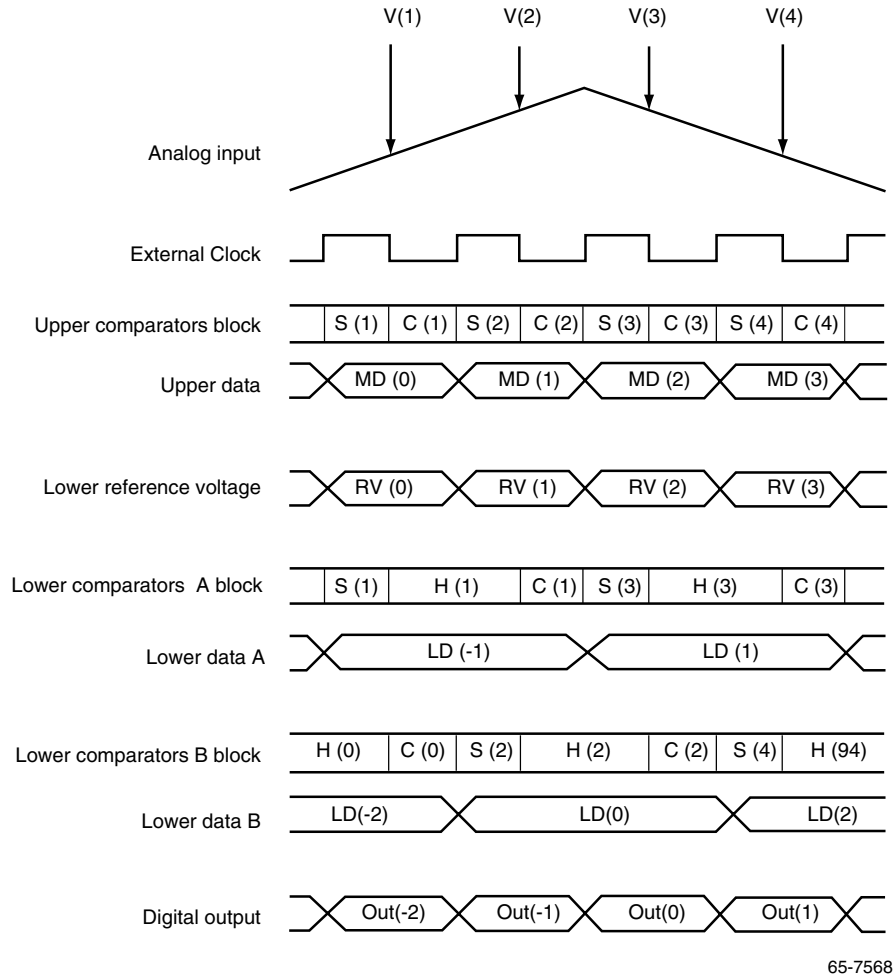

Figure 2. Conversion Timing



65-7568

Figure 3. Internal Timing

Pin Assignments

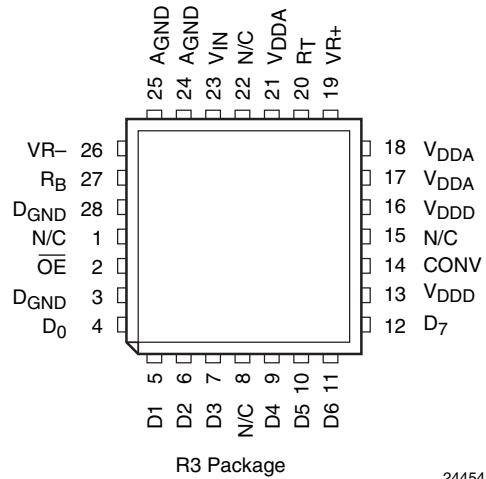
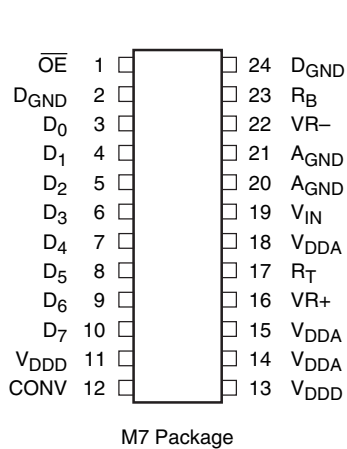

24454A

Pin Descriptions

Pin Name	Pin Number		Pin Type	Pin Function Description
	M7	R3		
Inputs				
V _{IN}	19	23	RT – RB	Analog Input. The input voltage conversion range lies between the voltages applied to the RT and RB pins.
RT	17	20	2.6V	Reference Voltage Top Input. RT is the top input to the reference resistor ladder. A DC voltage applied to RT defines the positive end of the V _{IN} conversion range.
RB	23	27	0.6V	Reference Voltage Bottom Input. RB is the bottom input to the reference resistor ladder. A DC voltage applied to RB defines the negative end of the V _{IN} conversion range.
VR+	16	19		Reference Voltage Top Source. VR+ is the internal pull-up reference resistor for self-bias operations.
VR–	22	26		Reference Voltage Bottom Source. VR– is the internal pull-down reference resistor for self-bias operations.
OE	1	2	CMOS	Output Enable. (CMOS-compatible) When LOW, D7-0 are enabled. When HIGH, D7-0 are in a high-impedance state.
CONV	12	14	CMOS	Convert (Clock) Input. (CMOS-compatible) V _{IN} is sampled on the falling edge of CONV.
Outputs				
D7-0	10–3	12–9, 7–4	CMOS/ TTL	Data Outputs (D7 = MSB). Eight-bit CMOS- and TTL-compatible digital outputs. Data is output following the rising edge of CONV.
Power				
VDDA	14, 15, 18	17, 18, 21	+5V	Analog Supply Voltage. Independent +5 volt power connection to analog comparator circuits.
VDDD	11, 13	13, 16	+5V	Digital Supply Voltage. Independent +5 volt power connection to digital error correction and output drivers.
AGND	20, 21	24, 25	0.0V	Analog Ground. Connect to the system analog ground plane.
DGND	2, 24	3, 28	0.0V	Digital Ground. Connect to the system analog ground plane.
No Connect				
N/C		1, 8, 15, 22	open	Not Connected.

Bandwidth Specification Notes

The specification for bandwidth of an A/D converter is somewhat different from the normal frequency-response specification used in amplifiers and filters. An understanding of the differences will help in selecting converters properly for particular applications.

A/D conversion comprises two distinct processes: *sampling* and *quantizing*. *Sampling* is “grabbing” a snapshot of the input signal and holding it steady for quantizing. The *quantizing* process is approximating the analog input, which may be any value within the conversion range, with its nearest numerical value. While sampling is a high-frequency process, quantizing operates on a dc signal, held steady by the track/hold circuit. Therefore, the sampling process is what relates to the dynamic characteristics of the converter.

Sampling involves an *aperture time*, the time during which the track/hold is trying to capture the input signal and settle on a dc value to hold. It is analogous to the shutter speed of a camera: the shorter the aperture (or faster the shutter) the less the signal will be blurred, and the less uncertainty there will be in the quantized value.

For example, a 10 MHz sinewave with a 1V peak amplitude (2Vp-p) has a maximum slew rate of $2\pi fA$ at zero crossing, or 62.8V/μs. With an 8-bit A/D converter, q (the quantization step size) = $2V/255 = 7.8mV$. The input signal will slew one LSB in 124ps. To limit the error (and noise) contribution due to *aperture effects* to 1/2LSB, the aperture must be shorter than 62ps.

This is the primary reason that the signal to noise ratio drops off as full scale frequency increases. Note, also, that the slew rate is directly proportional to signal amplitude, A. A/Ds will handle lower-amplitude signals of higher bandwidth.

All this is of particular interest in applications such as digitizing analog VGA RGB signals, or the output of a CCD imaging chip. These data are effectively pre-sampled: there is a period of rapid slewing from one pixel value to another, followed by a relatively stable dc level before the signal slews to the next pixel value. The goal is, of course, to

sample on these pixel values, not on the slewing between pixels. During the aperture time, the A/D sees essentially a dc signal, and classic bandwidth considerations are not important. As long as the input circuit can slew and settle to the new value in the prescribed period, an accurate conversion will be made.

The TMC1175A is capable of slewing a full 2V and settling between samples taken as little as 25ns apart, making it ideal for digitizing analog VGA and CCD outputs.

Equivalent Circuits and Threshold Level

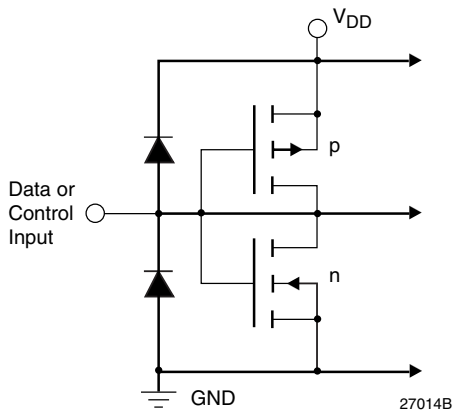

Figure 4. Equivalent Digital Input Circuit

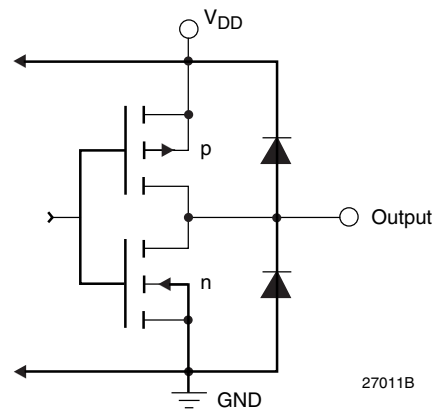

Figure 5. Equivalent Digital Output Circuit

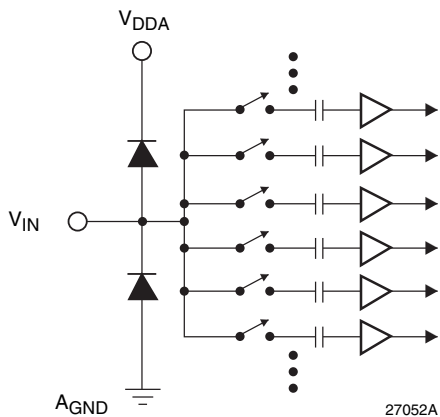

Figure 6. Equivalent Analog Input Circuit

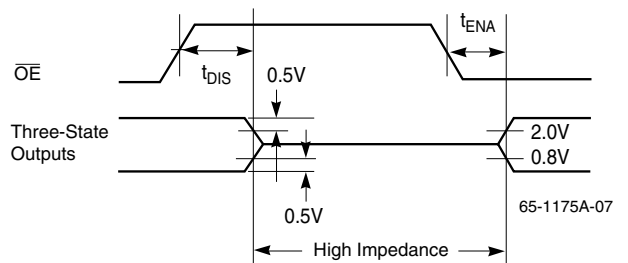

Figure 7. Threshold Levels for Three-State Measurements

Absolute Maximum Ratings

(beyond which the device may be damaged)¹

Parameter	Conditions	Min	Typ	Max	Unit
Power Supply Voltages					
VDDA	Measured to AGND	-0.5		7.0	V
VDDD	Measured to DGND	-0.5		7.0	
VDDA	Measured to VDDD	-0.5		0.5	V
AGND	Measured to DGND	-0.5		0.5	
Digital Inputs					
Applied Voltage ²	Measured to DGND	-0.5		VDDD + 0.5	V
Forced Current ^{3,4}		-10.0		10.0	mA
Analog Inputs					
Applied Voltage ²	Measured to AGND	-0.5		VDDA + 0.5	V
Forced Current ^{3,4}		-10.0		10.0	mA
Outputs					
Applied Voltage ²	Measured to DGND	-0.5		VDDD + 0.5	V
Forced Current ^{3,4}		-6.0		6.0	mA
Short Circuit Duration	Single output in HIGH state to ground			1	sec
Temperature					
Operating, Ambient		-20		110	°C
Junction				150	°C
Storage		-65		150	°C
Lead Soldering	10 seconds			300	°C
Vapor Phase Soldering	1 minute			220	°C

Notes:

- Functional operation under any of these conditions is NOT implied. Performance and reliability are guaranteed only if operating conditions are not exceeded.
- Applied voltage must be current limited to specified range.
- Forcing voltage must be limited to specified range.
- Current is specified as conventional current flowing into the device

Operating Conditions

Parameter		Min	Nom	Max	Units
V _{DDD}	Digital Power Supply Voltage	4.75	5.0	5.25	V
V _{DDA}	Analog Power Supply Voltage	4.75	5.0	5.25	V
AGND	Analog Ground (Measured to DGND)	-0.1	0	0.1	V
f _S	Conversion Rate	TMC1175A-20		20	MspS
		TMC1175A-30		30	MspS
		TMC1175A-40		40	MspS
t _{PWH}	CONV Pulsewidth, HIGH	TMC1175A-20	15		ns
		TMC1175A-30	13		ns
		TMC1175A-40	12		ns
t _{PWL}	CONV Pulsewidth, LOW	TMC1175A-20	15		ns
		TMC1175A-30	12		ns
		TMC1175A-40	12		ns
V _{RT}	Reference Voltage, Top	2.0	2.6	V _{DDA}	V
V _{RB}	Reference Voltage, Bottom	0	0.6	3.0	V
V _{RT-VRB}	Reference Voltage Differential	1.0		5.0	V
V _{IN}	Analog Input Range	V _{RB}		V _{RT}	V
V _{IH}	Input Voltage, Logic HIGH	0.7 x V _{DDD}		V _{DDD}	V
V _{IL}	Input Voltage, Logic LOW	GND		0.3 x V _{DDD}	V
I _{OH}	Output Current, Logic HIGH			-4.0	mA
I _{OL}	Output Current, Logic LOW			4.0	mA
T _A	Ambient Temperature, Still Air	-20		75	°C

Electrical Characteristics

Parameter		Conditions	Min	Typ ¹	Max	Units	
I _{DD}	Power Supply Current ¹	V _{DDD} = V _{DDA} = Max, C _{LOAD} = 35pF					
		f _S = 20MspS		20	30	mA	
		f _S = 30MspS			25	35	mA
		f _S = 40MspS			30	40	mA
I _{DDQ}	Power Supply Current, Quiescent	V _{DDD} = V _{DDA} = Max					
		CONV = LOW		7	18	mA	
		CONV = HIGH		10	20	mA	
P _D	Total Power Dissipation	V _{DDD} = V _{DDA} = Max, C _{LOAD} = 35pF					
		f _S = 20MspS		100	160	mW	
		f _S = 30MspS			125	185	mW
		f _S = 40MspS			150	210	mW
C _{AI}	Input Capacitance, Analog	CONV = LOW		4		pF	
		CONV = HIGH		12		pF	
R _{IN}	Input Resistance		500	1000		kΩ	

Electrical Characteristics (continued)

Parameter		Conditions	Min	Typ ¹	Max	Units
ICB	Input Current, Analog				±1	μA
RREF	Reference Resistance		200	270	340	Ω
I _{IH}	Input Current, HIGH	V _{DDD} = Max, V _{IN} = V _{DDD}			±5	μA
I _{IL}	Input Current, LOW	V _{DDD} = Max, V _{IN} = 0V			±5	μA
IOZH	Hi-Z Output Leakage	V _{DDD} = Max, V _{IN} = V _{DDD}			±5	μA
IOZL	Hi-Z Output Leakage	V _{DDD} = Max, V _{IN} = 0V			±5	μA
I _{OS}	Short-Circuit Current				-30	mA
VOH	Output Voltage, HIGH	I _{OH} = -100μA	V _{DDD} -0.3			V
		I _{OH} = -2.5mA	3.5			V
		I _{OH} = Max	2.4			V
VOL	Output Voltage, LOW	I _{OL} = Max			0.4	V
CDI	Digital Input Capacitance			4	10	pF
CDO	Digital Output Capacitance			10		pF

Note:

1. Typical values with V_{DDD} = V_{DDA} = Nom and T_A = Nom, Minimum/Maximum values with V_{DDD} = V_{DDA} = Max and T_A = Min.

Switching Characteristics

Parameter		Conditions	Min	Typ	Max	Units
t _{STO}	Sampling Time Offset		2	5	8	ns
t _{HO}	Output Hold Time	C _{LOAD} = 15pF	5			ns
t _{DO}	Output Delay Time	C _{LOAD} = 15pF			20	ns
t _{ENA}	Output Enable Time				27	ns
t _{DIS}	Output Disable Time				42	ns

System Performance Characteristics

Parameter		Conditions	Min	Typ ¹	Max	Units
E _{LI}	Integral Linearity Error, Independent	V _{RT} = 2.6V V _{RB} = 0.6V		±0.5	±1	LSB
E _{LD}	Differential Linearity Error	V _{RT} = 2.6V V _{RB} = 0.6V		±0.3	±1	LSB
BW	Bandwidth ²	TMC1175A-20 TMC1175A-30 TMC1175A-40			10 12 12	MHz MHz MHz
EAP	Aperture Error			30		ps
EOT	Offset Voltage, Top	R _T – V _{IN} for most positive code transition	-8	-25	-42	mV
EOB	Offset Voltage, Bottom	R _B – V _{IN} for most negative code transition	30	40	60	mV
dg	Differential Gain	f _S = 14.3Msps NTSC 40 IRE Mod Ramp V _{DDA} = +5.0V, T _A =25°C V _{RT} = 2.6V, V _{RB} = 0.6V		1.5	2.7	%
dp	Differential Phase	f _S = 14.3Msps NTSC 40 IRE Mod Ramp V _{DDA} = +5.0V, T _A =25°C V _{RT} = 2.6V, V _{RB} = 0.6V		0.5	1.0	deg
SNR ³	Signal-to-Noise Ratio	f _S = 20Msps, V _{RT} = 2.6V, V _{RB} = 0.6V				
		f _{IN} = 1.24MHz	44	48		dB
		f _{IN} = 2.48MHz	43	47		dB
		f _{IN} = 6.98MHz	41	45		dB
		f _{IN} = 10.0MHz	37	42		dB
		f _S = 30Msps, V _{RT} = 2.6V, V _{RB} = 0.6V				
		f _{IN} = 1.24MHz	42	47		dB
		f _{IN} = 2.48MHz	40	45		dB
		f _{IN} = 6.98MHz	38	43		dB
		f _{IN} = 10.0MHz	33	39		dB
		f _{IN} = 12.0MHz	30	37		dB
		f _S = 40Msps, V _{RT} = 2.6V, V _{RB} = 0.6V				
		f _{IN} = 1.24MHz	40	45		dB
		f _{IN} = 2.48MHz	38	43		dB
		f _{IN} = 6.98MHz	36	41		dB
f _{IN} = 10.0MHz	34	38		dB		
f _{IN} = 12.0MHz	32	36		dB		

System Performance Characteristics (continued)

Parameter	Conditions	Min	Typ ¹	Max	Units
SFDR ⁴ Spurious-Free Dynamic Range	f _S = 20Msps, V _{RT} = 2.6V, V _{RB} = 0.6V				
	f _{IN} = 1.24MHz	46	52		dB
	f _{IN} = 2.48MHz	44	51		dB
	f _{IN} = 6.98MHz	41	45		dB
	f _{IN} = 10.0MHz	38	43		dB
	f _S = 30Msps, V _{RT} = 2.6V, V _{RB} = 0.6V				
	f _{IN} = 1.24MHz	42	49		dB
	f _{IN} = 2.48MHz	40	45		dB
	f _{IN} = 6.98MHz	37	41		dB
	f _{IN} = 10.0MHz	35	40		dB
	f _{IN} = 12.0MHz	34	39		dB
	f _S = 40Msps, V _{RT} = 2.6V, V _{RB} = 0.6V				
	f _{IN} = 1.24MHz	40	44		dB
	f _{IN} = 2.48MHz	39	43		dB
	f _{IN} = 6.98MHz	38	41		dB
	f _{IN} = 10.0MHz	36	40		dB
	f _{IN} = 12.0MHz	36	39		dB

Notes:

1. Values shown in Typ column are typical for V_{DD} = V_{DDA} = +5V and T_A = 25°C.
2. Bandwidth is the frequency up to which a full-scale sinewave can be digitized without spurious codes.
3. SNR values do not include the harmonics of the fundamental frequency.
4. SFDR is the ratio in dB of fundamental amplitude to the harmonic with the highest amplitude.

Typical Performance Characteristics

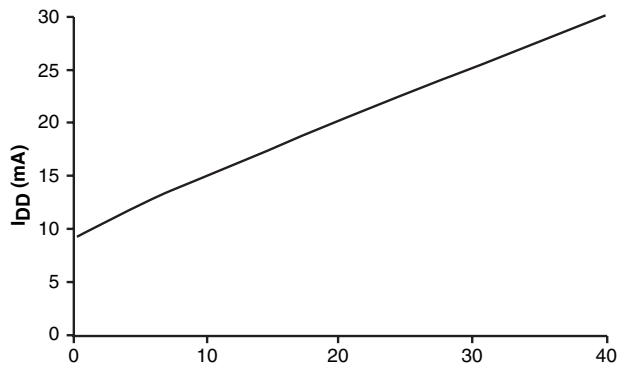

Figure 8. Typical I_{DD} vs f_s

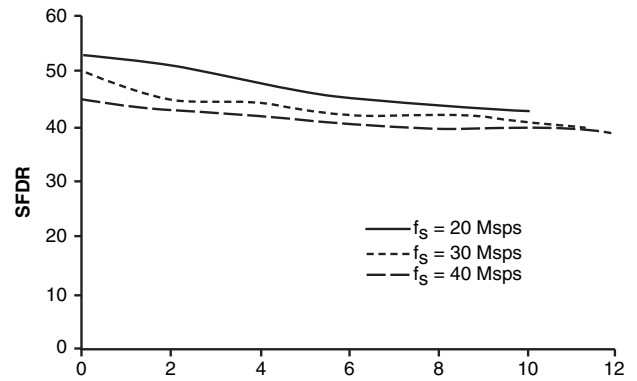

Figure 9. Typical SFDR vs f_{IN} and f_s

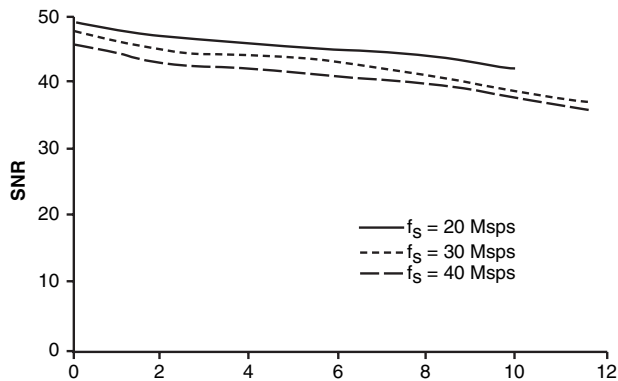

Figure 10. Typical SNR vs f_{IN} and f_s

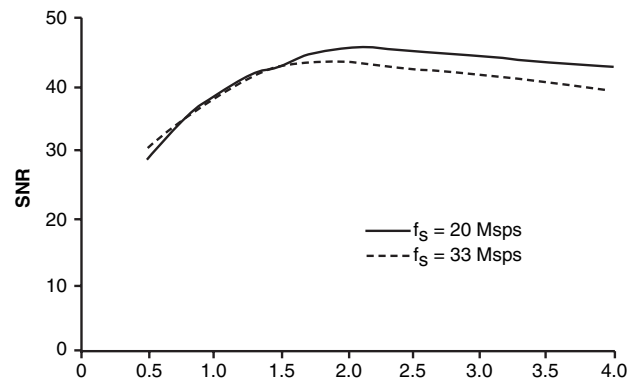

Figure 11. Typical SNR vs Full Scale Input Range

Applications Discussion

The circuit in Figure 12 employs a band-gap reference to generate a variable R_T reference voltages for the TMC1175A as well as a bias voltage to offset the wideband input amplifier to mid-range. An "offset adjust" is also shown for varying the mid-range voltage level. The operational amplifier in the reference circuitry is a standard 741-type.

The voltage reference at R_T can be adjusted from 0.0 to 2.4 volts while R_B is grounded. Diodes are used to restrict the wideband amplifier output to between $-0.7V$ and $V_{DD} + 0.7V$. Diode protection is good practice to limit the analog input voltage at V_{IN} to the safe operating range.

The circuit in Figure 13 shows self-bias of R_T and R_B by connection to $VR+$ and $VR-$. This sets up a 0.6 to 2.6 Volt input range for V_{IN} . The input range is susceptible to power supply variation since the voltages on R_T and R_B are directly derived from V_{DDA} . The video input is AC-coupled and biased at an adjustable midpoint of the A/D input range. This circuit offers the advantage of minimum support circuitry for the most cost-sensitive applications.

In Figure 14, an external band-gap reference sets R_T to $+1.2$ Volts while R_B is grounded. The internal pull-up resistor, $R+$, provides the bias current for the band-gap reference. The A/D converter input is biased to the mid-point of the input range.

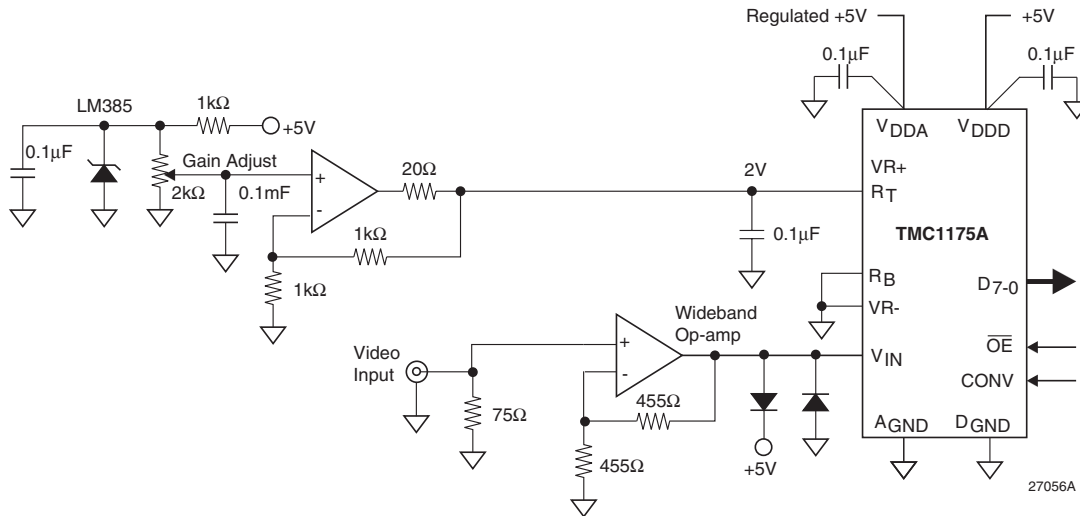

Figure 12. Typical Interface Circuit-High Performance

Grounding

The TMC1175A has separate analog and digital circuits. To keep digital system noise from the A/D converter, it is recommended that power supply voltages (VDDD and VDDA) originate from separate sources with VDDA regulated, and that ground connections (DGND and AGND) be made to the analog ground plane. Power supply pins should be individually decoupled at the pin. The digital circuitry that gets its input from the TMC1175A should be referred to the system digital ground plane.

Printed Circuit Board Layout

Designing with high performance mixed-signal circuits demands printed circuits with ground planes. Wire-wrap is not an option, even for breadboarding. Overall system performance is strongly influenced by the board layout. Capacitive coupling from digital to analog circuits may result in poor A/D conversion. Consider the following suggestions when doing the layout:

1. Keep the critical analog traces (V_{IN}, R_T, R_B, V_{R+}, V_{R-}) as short as possible and as far as possible from all digital signals. The TMC1175A should be located near the board edge, close to the analog input connectors.
2. The power plane for the TMC1175A should be separate from that which supplies the rest of the digital circuitry. A single power plane should be used for all of the VDD pins. If the power supply for the TMC1175A is the same as that of the system's digital circuitry, power to the TMC1175A should be decoupled with ferrite beads and 0.1μF capacitors to reduce noise.
3. The ground plane should be solid, not cross-hatched. Connections to the ground plane should have very short leads.

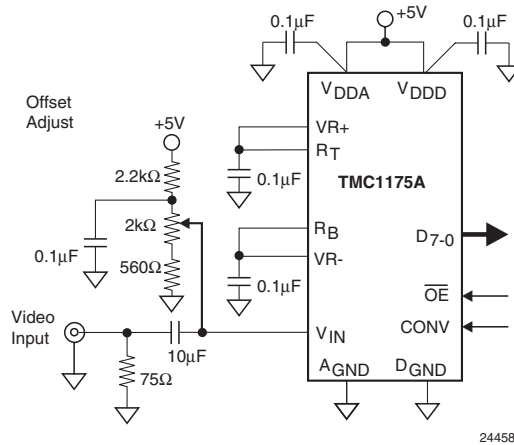

Figure 13. Typical Interface Circuit - Low Cost

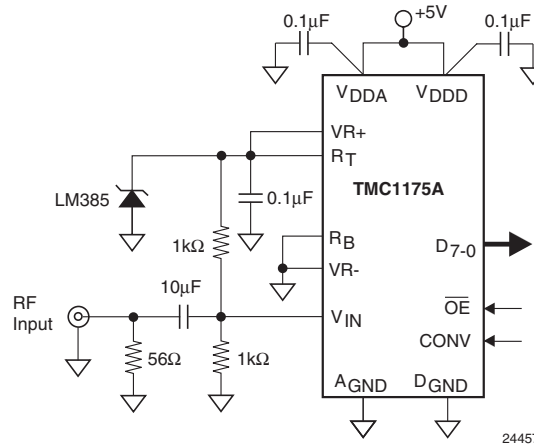

Figure 14. Typical Interface Circuit - Stabilized Reference

4. Decoupling capacitors should be applied liberally to VDD pins. Remember that not all power supply pins are created equal. They supply different circuits on the integrated circuit, each of which generate varying amounts and types of noise. For best results, use 0.1 μ F ceramic capacitors. Lead lengths should be minimized. Ceramic chip capacitors are the best choice.
5. If the digital power supply has a dedicated power plane layer, it should not be placed under the TMC1175A, the voltage reference, or the analog inputs. Capacitive coupling of digital power supply noise from this layer to the TMC1175A and its related analog circuitry can have an adverse effect on performance.
6. CONV should be handled carefully. Jitter and noise on this clock may degrade performance. Terminate the clock line at the CONV input, if required, to eliminate overshoot and ringing.

Evaluation Board

An evaluation board is available that implements good interface practices and provide a convenient testbed for developing system applications and circuit variations. An on-board D/A converter is provided to reconstruct the digitized signal and to evaluate converter performance.

Contact your sales representative for information.

Mechanical Dimensions

24 Lead SOIC (5.4 mm) Package

Symbol	Inches		Millimeters		Notes
	Min.	Max.	Min.	Max.	
A	.067	.075	1.70	1.90	
A1	.004	.012	0.10	0.31	
B	.014	.020	0.36	0.51	
C	.006	.012	0.15	0.30	
D	.587	.610	14.90	15.50	
E	.205	.220	5.20	5.60	
E1	.295	.319	7.50	8.10	
e	.050 BSC		1.27 BSC		
h	.010	.020	0.25	0.50	
L	.016	.050	0.41	1.27	
N	24		24		
α°	0	8	0	8	
ccc	-	.004	-	0.10	

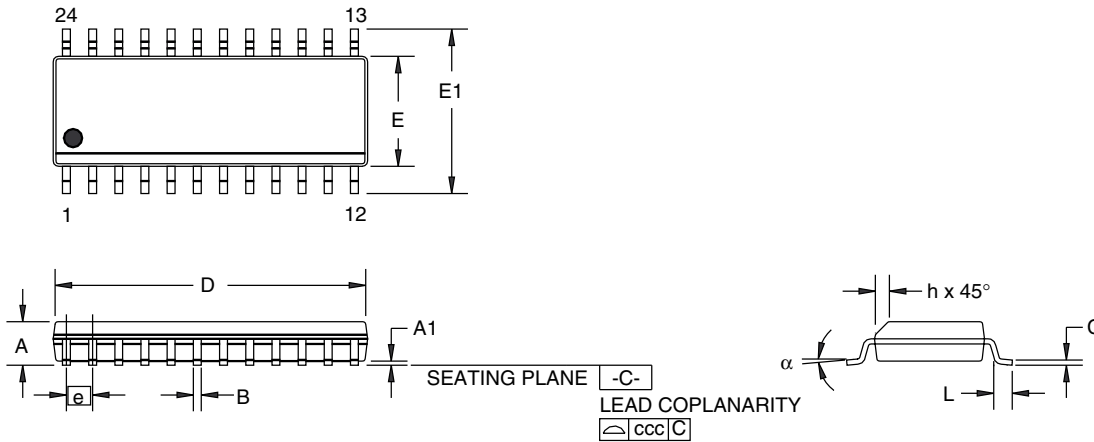

Mechanical Dimensions (continued)

28 Lead PLCC Package

Symbol	Inches		Millimeters		Notes
	Min.	Max.	Min.	Max.	
A	.165	.180	4.19	4.57	
A1	.090	.120	2.29	3.05	
A2	.020	—	.51	—	
B	.013	.021	.33	.53	
B1	.026	.032	.66	.81	
D/E	.485	.495	12.32	12.57	
D1/E1	.450	.456	11.43	11.58	3
D3/E3	.300 BSC		7.62 BSC		
e	.050 BSC		1.27 BSC		
J	.042	.048	1.07	1.22	2
ND/NE	7		7		
N	28		28		
ccc	—	.004	—	0.10	

Notes:

1. All dimensions and tolerances conform to ANSI Y14.5M-1982
2. Corner and edge chamfer (J) = 45°
3. Dimension D1 and E1 do not include mold protrusion. Allowable protrusion is .101" (.25mm)

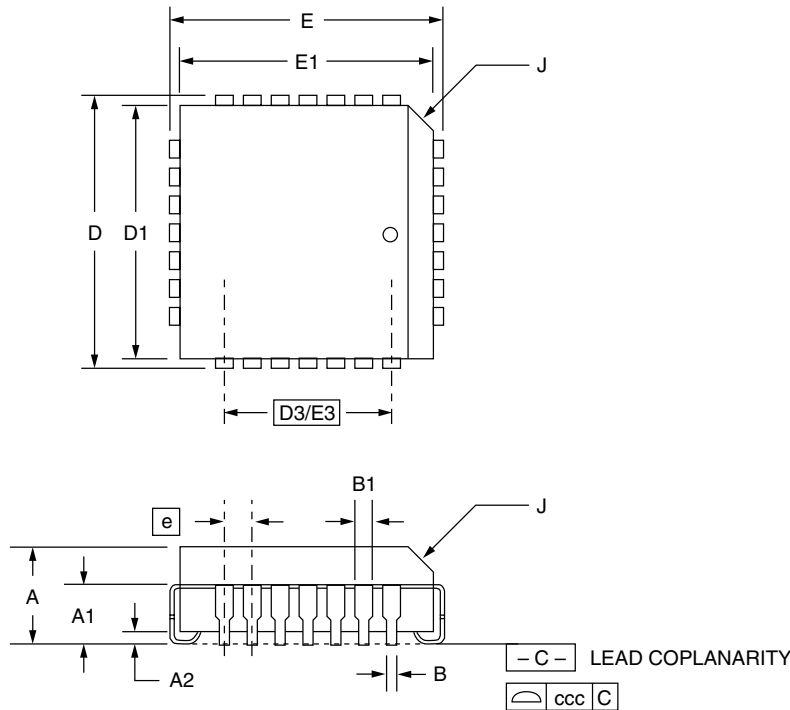

Ordering Information

Product Number	Conversion Rate	Temperature Range	Screening	Package	Package Marking
TMC1175AM7C20	20 Msps	T _A = -20°C to 75°C	Commercial	24-Lead SOIC	1175AM7C20
TMC1175AM7C30	30 Msps	T _A = -20°C to 75°C	Commercial	24-Lead SOIC	1175AM7C30
TMC1175AM7C40	40 Msps	T _A = -20°C to 75°C	Commercial	24-Lead SOIC	1175AM7C40
TMC1175AR3C20	20 Msps	T _A = -20°C to 75°C	Commercial	28-Lead PLCC	1175AR3C20
TMC1175AR3C30	30 Msps	T _A = -20°C to 75°C	Commercial	28-Lead PLCC	1175AR3C30
TMC1175AR3C40	40 Msps	T _A = -20°C to 75°C	Commercial	28-Lead PLCC	1175AR3C40

Addendum 03/03/09

CADEKA Adds New Package Option

TMC1175AW7C20	20 Msps	T _A = -20°C to 75°C	Commercial	24-Lead SOIC (0.300 wide body SOIC)	1175AW7C20
---------------	---------	--------------------------------	------------	-------------------------------------	------------

24 Lead SOIC, 0.300 Wide Body Package

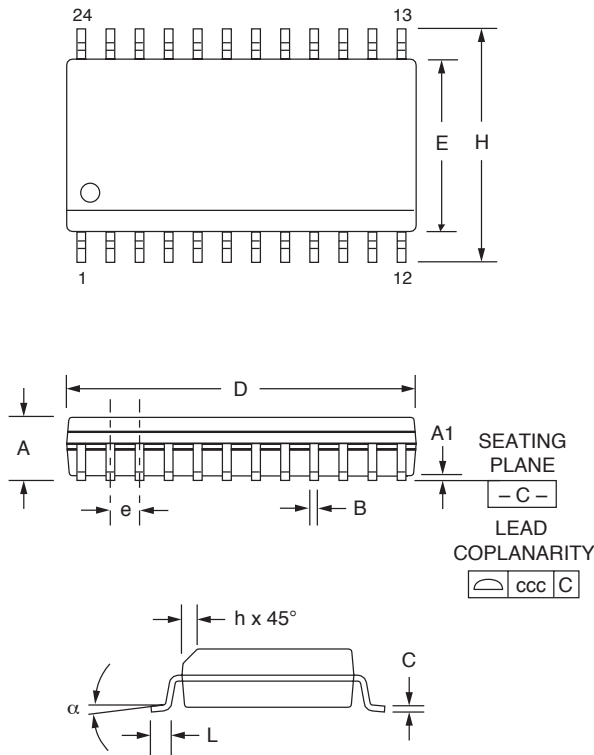

Symbol	Inches		Millimeters		Notes
	Min.	Max.	Min.	Max.	
A	.093	.104	2.35	2.65	
A1	.004	.012	0.10	0.30	
B	.013	.020	0.33	0.51	
C	.009	.013	0.23	0.32	5
D	.599	.614	15.20	15.60	2
E	.290	.299	7.36	7.60	2
e	.050 BSC		1.27 BSC		
H	.394	.419	10.00	10.65	
h	.010	.020	0.25	0.51	
L	.016	.050	0.40	1.27	3
N	24		24		6
α	0°	8°	0°	8°	
ccc	—	.004	—	0.10	

Notes:

1. Dimensioning and tolerancing per ANSI Y14.5M-1982.
2. "D" and "E" do not include mold flash. Mold flash or protrusions shall not exceed .010 inch (0.25mm).
3. "L" is the length of terminal for soldering to a substrate.
4. Terminal numbers are shown for reference only.
5. "C" dimension does not include solder finish thickness.
6. Symbol "N" is the maximum number of terminals.

For additional information regarding our products, please visit CADEKA at: cadeka.com

CADEKA Headquarters Loveland, Colorado

T: 970.663.5452

T: 877.663.5452 (toll free)

CADEKA, the CADEKA logo design, COMLINEAR and the COMLINEAR logo design are trademarks or registered trademarks of CADEKA Microcircuits LLC. All other brand and product names may be trademarks of their respective companies.

CADEKA reserves the right to make changes to any products and services herein at any time without notice. CADEKA does not assume any responsibility or liability arising out of the application or use of any product or service described herein, except as expressly agreed to in writing by CADEKA; nor does the purchase, lease, or use of a product or service from CADEKA convey a license under any patent rights, copyrights, trademark rights, or any other of the intellectual property rights of CADEKA or of third parties.

Copyright ©2009 by CADEKA Microcircuits LLC. All rights reserved.

