

# TMC2072

## Genlocking Video Digitizer

### Features

- Fully integrated acquisition
- 3-channel video input multiplexer
- Two-stage (analog and digital) video clamp
- Automatic gain adjustment
- Sync detection and separation
- Pixel and subpixel adjustment of video-to-sync output timing
- Genlock to any NTSC or PAL format, including PAL-M and PAL-N
- Pixel clock generation
- 8-bit video A/D conversion
- Standard R-bus serial microprocessor interface
- User-selectable line-locked pixel rates include:
  - 12.27 MHz NTSC & PAL-M
  - 13.5 MHz NTSC & all PAL
  - 14.75 MHz PAL (non-M) TMC2072-1 only
  - 15.0 MHz PAL (non-M) TMC2072-1 only
- Direct interface to Fairchild Semiconductor video encoders and decoders
- Built-in circuitry for crystal oscillator
- No tuning or external voltage reference required
- Space-saving 100-lead MQFP package

### Applications

- Frame grabber
- Digital videotape recorders
- Desktop video

### Description

The TMC2072 Genlocking Video Digitizer samples and quantizes standard analog baseband composite NTSC or PAL video into its 8-bit digital equivalent. It extracts horizontal and vertical sync signals, from which an on-chip PLL generates a line-locked pixel clock for the on-chip 8-bit A/D converter and a double-speed register clock to transfer data to a subsequent video processing subsystem. A second PLL generates a chroma subcarrier locked to the incoming chroma burst. The chip reports each line's color burst phase and frequency during the next horizontal sync pulse.

The TMC2072 includes a three-channel video input multiplexer, analog clamp, variable gain amplifier, and digital back porch clamp. The user may provide either an external 20MHz clock or a 20MHz crystal. No external component changes or tuning are required for PAL or NTSC operation at either D1 or square pixel VGA pixel rates.

The TMC2072 is fabricated in a submicron CMOS process and is packaged in a 100-lead MQFP. Its performance is guaranteed from 0 to 70°C.

### Block Diagram

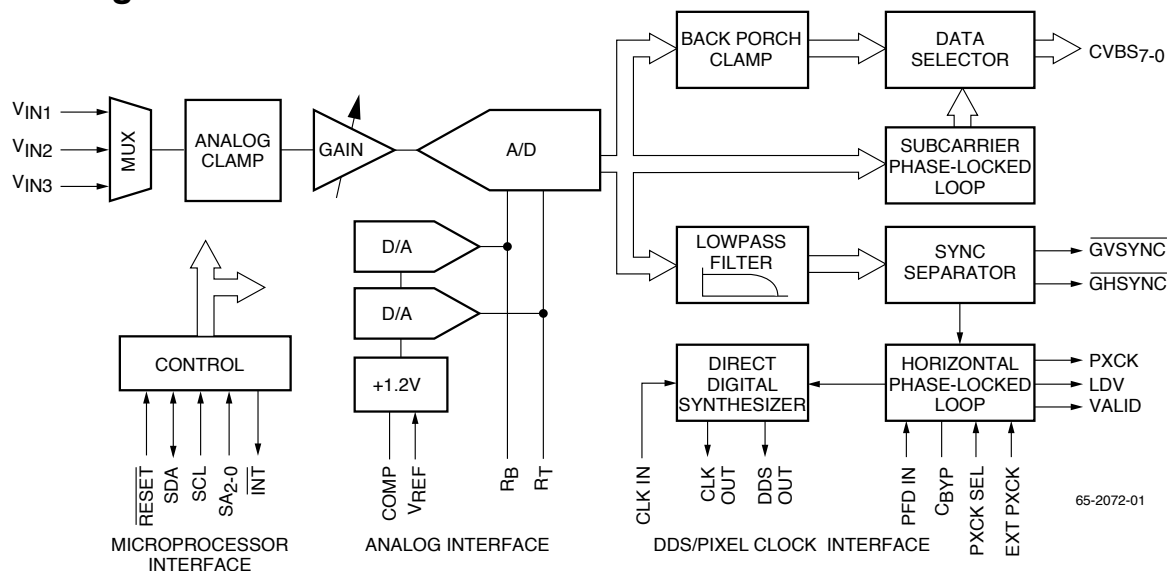

## Functional Description

The TMC2072, a fully integrated self-genlocking video A/D converter, digitizes NTSC or PAL baseband composite signals. It accepts video on one of three input channels, adjusts the gain, clamps to the back porch and digitizes the video at a user-selectable multiple of the horizontal line frequency. It extracts horizontal and vertical sync, measures the subcarrier frequency and phase, and provides these data with the digitized composite data over an 8-bit digital video port. Horizontal and vertical sync outputs are provided, along with pixel clock (LDV) and twice pixel clock (PXCK).

Operating parameters are set up via a standard two-wire microprocessor port. The chip can work with either an internal or an external voltage reference.

Fabricated in an advanced CMOS process, the TMC2072 is housed in a 100 lead metric quad flat package. Its performance is guaranteed from 0 to 70°C and from 4.75 to 5.25 supply volts.

### Timing

The TMC2072's A/D converter and digital signal path operate from alternate cycles of an internally-synthesized clock, PXCK. This 24.5 to 30 MHz clock is derived from the incoming 20 MHz reference clock and phase-locked to the horizontal sync tips of the incoming analog video stream. The frequency of PXCK may be set as 1560 (NTSC VGA square pixel), 1716 (NTSC D1), 1732 (PAL D1), or 1888 or 1920 (PAL VGA) times the incoming video line rate.

Timing of the serial microprocessor interface bus is independent of the pixel clock and is described under the Microprocessor Interface section that follows Functional Description.

### Video Input

Via the microprocessor interface, the user can enable one of the chip's three analog video input ports. Although each port normally anticipates a standard video signal level with 286 to 300 mV between sync tip and blank, another control register bit allows it to be used with half-power (approximately 70% amplitude) signals. Good crosstalk isolation accommodates active video on all three inputs simultaneously. The user must provide antialias filtering and proper line termination externally.

### Analog Clamp

The front-end analog clamp ensures that the input video falls within the active range of the A/D converter. The digitized composite video output can be clamped to the back porch by a secondary digital clamp.

### Automatic Gain Adjustment

To accommodate approximately a  $\pm 15\%$  range in video signal amplitudes, the TMC2072's on-chip AGC circuit

engages for one video frame following either: 1) initial lock after reset; 2) loss and recovery of lock while operating; or 3) setting of control bit AGCEN high by the host microprocessor. The AGC operation adjusts the A/D converter's on-chip reference voltages until video blank causes it to output approximately 1/4 of its full range. The chip then holds this gain adjustment constant until a new AGC sequence is initiated by AGCEN going high or by loss and recovery of video lock. The one-frame timeout prevents the gain control from riding gain and trying to track noise or minor variations in signal strength.

To handle doubly-terminated and other weak video signals, the user should set the VGAIN control bit high, thereby boosting video gain 50% above nominal.

### Analog-to-Digital Converter

The TMC2072 contains a high-performance 8-bit A/D converter. Its gain and offset are automatically set as a part of the automatic gain adjustment process during initial signal acquisition, and require no user attention.

The reference voltages to the A/D converter are set up by internal D/A converters under automatic control during genlock acquisition. These voltages determine the gain and offset of the A/D converter with respect to the video level presented at its input.

### Low-Pass Filter

The digitized composite video stream is digitally low-pass filtered to remove chrominance components from the sync separator. Filtering provides robust operation by optimizing the signal-to-noise ratio of the synchronizing/blanking portion of the video, improving the accuracy of the back porch blanking level detector.

A digital sync separator provides the output sync signals, GHSYNC and GVSYNC, and times internal operations.

### Horizontal Phase-Locked Loop

A phase-locked loop generates PXCK, at twice the pixel rate. The reference signal for the horizontal phase-locked loop is generated by the Direct Digital Synthesizer (DDS). The DDS output is constructed with an internal D/A converter and is output from the TMC2072 via the DDS OUT pin. This signal is passed through an external LC filter and input to the horizontal phase-comparator.

The frequency of the DDS output is one ninth of that of PXCK.

A 20MHz clock is required to drive the DDS. Preferably, this may be input to the TMC2072 via CMOS levels on the CLK IN pin. Alternately, a 20MHz crystal may be directly connected between CLK IN and CLK OUT with tuning capacitors to activate the internal crystal oscillator circuitry.

If incoming video is lost or disconnected after the TMC2072 has locked to it, PXCK and GRS data will continue, but  $\overline{\text{VSYNC}}$  and every eighth  $\overline{\text{HSYNC}}$  will cease until lock is reestablished. The GRS will report the initial subcarrier frequency set by the Format select bits of the Control Register. The TMC2072 will relock to incoming video within two frames after it is restored.

**Subcarrier Phase-Locked Loop**

A fully-digital phase-locked loop is used to extract the phase and frequency of the incoming color burst. These frequency and phase values are output over the CVBS bus during the horizontal sync period. Fairchild’s video decoder and gen-lockable encoder chips will accept these data directly.

**Back Porch Digital Clamp**

A digital back-porch clamp is employed to ensure a constant blanking level. It digitally offsets the data from the A/D converter to set the back porch level to precisely 3Ch for NTSC and 40h for PAL. When the digital clamp is enabled, the CVBS video output data is the A/D conversion result minus the back porch level plus 3Ch (40h for PAL). The back-porch level is low-pass filtered to minimize streaking artifacts from subtle line-to-line variations.

**Digitized Video Output**

The digitized 8-bit video output is provided over an 8-bit wide CVBS data port, synchronous with PXCK and LDV. Subcarrier frequency, subcarrier phase, and Field ID data (GRS) are transmitted in 4-bit nibbles over CVBS3-0 during the horizontal sync tip period at the PXCK rate.

**Microprocessor Interface**

The TMC2072 is controlled by a standard 2-wire bus. Up to eight TMC2072 devices may be connected to the 2-wire serial interface with each device having a unique address.

The 2-wire interface comprises a clock input (SCL) and a bi-directional data (SDA) pin. The TMC2072 acts as a slave

for receiving and transmitting data over the serial interface. When the serial interface is not active, the logic levels on SCL and SDA are pulled HIGH by external pull-up resistors.

Data received or transmitted on the SDA line must be stable for the duration of the positive-going SCL pulse. Data on SDA must change only when SCL is LOW. If SDA changes state while SCL is HIGH, the serial interface interprets that action as a start or stop sequence.

There are five components to serial bus operation:

- Start signal
- Slave address byte
- Base register address byte
- Data byte to read or write
- Stop signal

When the serial interface is inactive (SCL and SDA are HIGH) communications are initiated by sending a start signal. The start signal is a HIGH-to-LOW transition on SDA while SCL is HIGH. This signal alerts all slaved devices that a data transfer sequence is coming.

The first eight bits of data transferred after a start signal comprise a seven bit slave address and a single R/W bit. The R/W bit indicates the direction of data transfer, read from or write to the slave device. If the transmitted slave address matches the address of the device (set by the state of the SA2:0 input pins.), the TMC2072 acknowledges by bringing SDA LOW on the 9th SCL pulse. If the addresses do not match, the TMC2072 does not acknowledge.

**Table 1. Serial Port Addresses**

A6	A5	A4	A3	A2 (SA2)	A1 (SA1)	A0 (SA0)
1	0	0	0	1/0	1/0	1/0

The address is 1000 SA2 SA1 SA0.

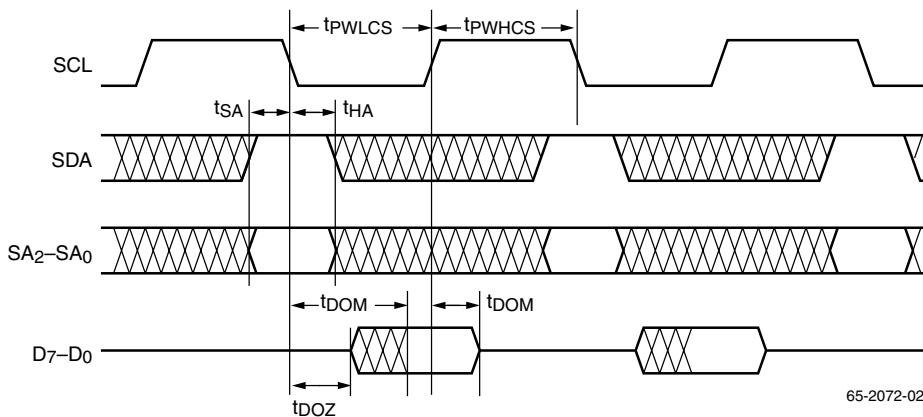

**Figure 1. Microprocessor Parallel Port – Read Timing**

### Data Transfer via Serial Interface

For each byte of data read or written, the MSB is the first bit of the sequence.

If the TMC2072 does not acknowledge the master device during a write sequence, the SDA remains HIGH so the master can generate a stop signal. If the master device does not acknowledge the TMC2072 during a read sequence, the TMC2072 interprets this as “end of data.” The SDA remains HIGH so the master can generate a stop signal.

Writing data to specific control registers of the TMC2072 requires that the 8-bit address of the control register of interest be written after the slave address has been established. This control register address is the base address for subsequent write operations. The base address autoincrements by one for each byte of data written after the data byte intended for the base address. If more bytes are transferred than there are available addresses, the address will not increment and remain at its maximum value of 10h. Any base address higher than 10h will not produce an ACKnowledge signal. If no ACKnowledge is received from the master, the encoder will automatically stop sending data.

Data are read from the control registers of the TMC2072 in a similar manner. Reading requires two data transfer operations:

The base address must be written with the R/W bit of the slave address byte LOW to set up a sequential read operation.

Reading (the R/W bit of the slave address byte HIGH) begins at the previously established base address. The address of the read register autoincrements after each byte is transferred.

To terminate a read/write sequence to the TMC2072, a stop signal must be sent. A stop signal comprises a LOW-to-HIGH transition of SDA while SCL is HIGH.

A repeated start signal occurs when the master device driving the serial interface generates a start signal without first generating a stop signal to terminate the current communication. This is used to change the mode of communication (read, write) between the slave and master without releasing the serial interface lines.

### Serial Interface Read/Write Examples

Write to one control register

- ↓ Start signal
- ↓ Slave Address byte (R/W bit = LOW)
- ↓ Base Address byte
- ↓ Data byte to base address
- ↓ Stop signal

Write to four consecutive control registers

- ↓ Start signal
- ↓ Slave Address byte (R/W bit = LOW)
- ↓ Base Address byte
- ↓ Data byte to base address
- ↓ Data byte to (base address + 1)
- ↓ Data byte to (base address + 2)
- ↓ Data byte to (base address + 3)
- ↓ Stop signal

Read from one control register

- ↓ Start signal
- ↓ Slave Address byte (R/W bit = LOW)
- ↓ Base Address byte

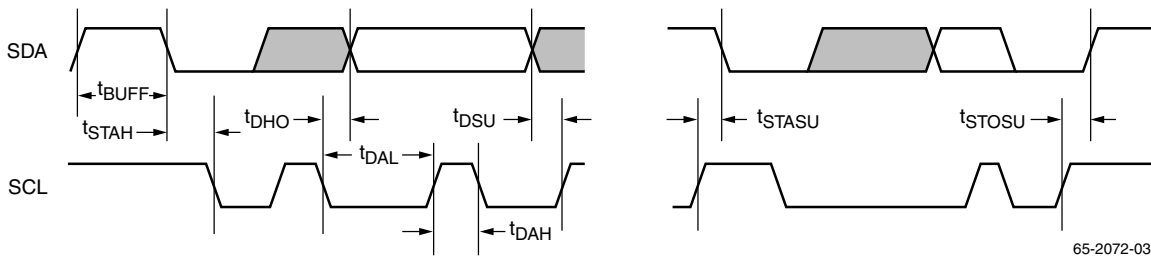

Figure 2. Serial Port Read/Write Timing

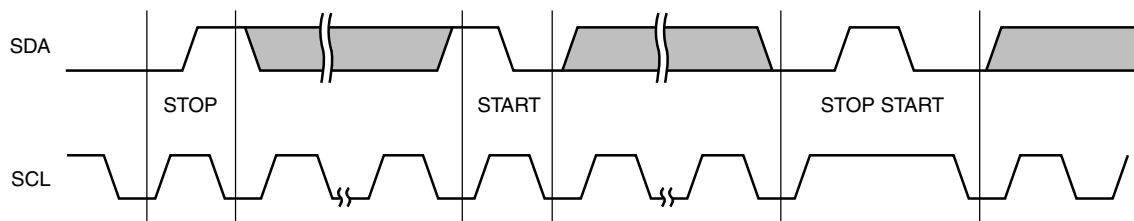
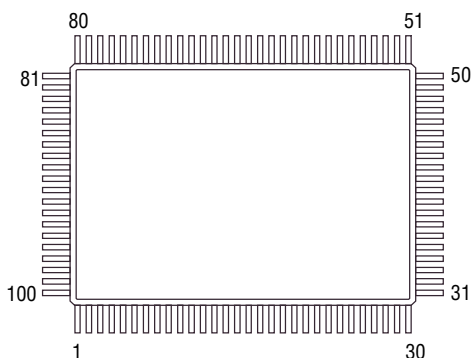

Figure 3. Serial Interface – Start/Stop Signal

- ↓ Stop signal
  - ↓ Start signal
  - ↓ Slave Address byte (R/W bit = HIGH)
  - ↓ Data byte from base address
  - ↓ Stop signal
- Read from four consecutive control registers
- ↓ Start signal
  - ↓ Slave Address byte (R/W bit = LOW)
  - ↓ Base Address byte

- ↓ Stop signal
- ↓ Start signal
- ↓ Slave Address byte (R/W bit = HIGH)
- ↓ Data byte from base address
- ↓ Data byte from (base address + 1)
- ↓ Data byte from (base address + 2)
- ↓ Data byte from (base address + 3)
- ↓ Stop signal

## Pin Assignments



**Note:**

1. NC = No internal connection between package and IC. Fairchild Semiconductor recommends leaving these pins open to simplify board upgrades to potential future genlock chips.

Pin	Name	Pin	Name	Pin	Name	Pin	Name
1	SA0	26	VDD	51	VDDA	76	NC
2	SA1	27	DGND	52	VDDA	77	PFD IN
3	SA2	28	CVBS5	53	NC	78	NC
4	SDA	29	CVBS6	54	NC	79	NC
5	SCL	30	CVBS7	55	AGND	80	NC
6	VDD	31	BURL	56	NC	81	AGND
7	RESET	32	GHSYNC	57	RB	82	DDS OUT
8	DGND	33	GVSYNC	58	VIN3	83	NC
9	NC	34	VALID	59	NC	84	NC
10	NC	35	FID0	60	VDDA	85	NC
11	NC	36	FID1	61	VIN2	86	PXCK SEL
12	NC	37	NC	62	NC	87	VDDA
13	NC	38	DGND	63	AGND	88	COMP
14	NC	39	DGND	64	VDDA	89	AGND
15	NC	40	LDV	65	VIN1	90	DGND
16	DGND	41	DGND	66	NC	91	CLK IN
17	INT	42	VDD	67	AGND	92	VDD
18	VDD	43	NC	68	RT	93	CLK OUT
19	NC	44	VDD	69	AGND	94	EXT PXCK
20	NC	45	PXCK	70	VREF	95	DGND
21	CVBS0	46	DGND	71	NC	96	DGND
22	CVBS1	47	DGND	72	AGND	97	DGND
23	CVBS2	48	VDD	73	VDDA	98	VDD
24	CVBS3	49	VDDA	74	AGND	99	NC
25	CVBS4	50	AGND	75	CBYP	100	VDD

65-2072-05

## Pin Definitions

Pin Name	Pin Number	Pin Type	Function
<b>Video Input</b>			
VIN1-3	65, 61, 58	1.23Vp-p	<b>Composite Video Input.</b> Video inputs, 1.235 Volts peak-to-peak, sync tip to peak color
<b>Clocks</b>			
CLK IN	91	CMOS	<b>20 MHz DDS clock input.</b> 20 MHz CMOS clock input to DDS. This pin may also be used along with $\overline{\text{CLK}}$ OUT for directly connecting crystals.
CLK OUT	93	CMOS	<b>Inverted clock output.</b> Inverted DDS clock output. This pin may also be used along with CLK IN for directly connecting a crystal.
PXCK	45	CMOS	<b>2x Pixel clock output.</b> 2x oversampled line-locked clock output.

**Pin Definitions** (continued)

Pin Name	Pin Number	Pin Type	Function						
LDV	40	CMOS	<b>Pixel clock output.</b> Delayed pixel clock output. LDV runs at 1/2 the rate of PXCK and its rising edge is useful for transferring CVBS digital video from the TMC2072 to the TMC22x9x Digital Video Encoders.						
EXT PXCK	94	CMOS	<b>External PXCK input.</b> Input for external PXCK clock source.						
PXCK SEL	86	CMOS	<b>PXCK source select.</b> Select input for internal or external PXCK. When HIGH, the internally generated line-locked PXCK is selected. When LOW, the external PXCK source is enabled.						
<b>Digital Video</b>									
GHSYNC	32	CMOS	<b>Horizontal sync output.</b> When the TMC2072 is locked to incoming video, the GHSYNC pin provides a negative-going pulse after the falling edge of each horizontal sync pulse. When the device is locked to a stable video signal, there is a fixed number of PXCK clock cycles between adjacent falling edges of $\overline{\text{GHSYNC}}$ . If no video signal is present and LEADLAG is less than 4A(hex), the TMC2072 will output normal, evenly-spaced horizontal pulses. If no video signal is present and LEADLAG exceeds 88(hex), the TMC2072 will omit every eighth Hsync pulse. As LEADLAG is increased from 49h to 89h, seven out of every eight Hsyncs will be unaffected, but the eighth will shrink by one clock cycle per LSB step, until it disappears entirely at 89h.						
GVSYNC	33	CMOS	<b>Vertical sync output.</b> When the TMC2072 is locked to incoming video, the GVSYNC pin provides a negative-going edge after the start of the first vertical sync pulse of a vertical blanking interval. If no video signal is present on the selected input pin, GVSYNC will remain continuously at logic high, until a signal is selected and lock is reestablished. A system designer requiring a free-running vertical sync may wish to provide this with an external pixel counter.						
CVBS7-0	30-28, 25-21	CMOS	<b>Composite output bus.</b> 8-bit composite video data are output on this bus at 1/2 the PXCK rate. During horizontal sync, field ID, subcarrier frequency, and subcarrier phase are available on this bus.						
FID[0]	35	CMOS	Odd/even (“top/bottom”) field flag. LOW denotes the first field of a video frame; HIGH, the second.						
FID[1]	36	CMOS	Burch blanking flag. In PAL, LOW denotes a frame with burst blanked on line 310, whereas HIGH denotes burst detected on line 310. FID[1] is valid only in PAL and only when FID[0] is high and should be interpreted as follows: <table border="1" data-bbox="699 1543 1182 1665"> <thead> <tr> <th>FID[1:0]</th> <th>PAL Field Number</th> </tr> </thead> <tbody> <tr> <td>01</td> <td>II or VI</td> </tr> <tr> <td>11</td> <td>IV or VIII</td> </tr> </tbody> </table>	FID[1:0]	PAL Field Number	01	II or VI	11	IV or VIII
FID[1:0]	PAL Field Number								
01	II or VI								
11	IV or VIII								
<b>μP I/O</b>									
SA[2:0]	3-1		<b>R-bus chip address, 3 LSBs.</b> Full 7-bit address = {1, 0, 0, 0, SA[2], SA[1], SA[0]}						
SDA	4	R-bus	<b>R-bus bidirectional data line.</b>						
SCL	5	R-bus	<b>R-bus clock line (input/slave only)</b>						

**Pin Definitions** (continued)

Pin Name	Pin Number	Pin Type	Function
RESET	7	TTL	<b>Master reset input.</b> Bringing RESET LOW forces the internal state machines to their starting states, loads the Control Register with default values, and disables outputs. Bringing RESET HIGH restarts the TMC2072 in its default mode.
INT	17	TTL	<b>Interrupt output.</b> This output is LOW if the internal horizontal phase lock loop is unlocked with respect to incoming video for 128 or more lines per field. After lock is established, INT goes HIGH.
VALID	34	TTL	<b>HSYNC locked flag.</b> Hsync locked flag. When high, this output indicates that the most recent incoming horizontal sync has been detected within $\pm 16$ pixels of its expected position. It goes low if no sync is encountered during this $\pm 16$ -pixel window, as during a typical VCR headswitch line. Once the chip has locked to a clean video source, this flag should remain high continuously. If the chip has locked to a VCR, this flag will typically go low for one (or sometimes two) lines at the bottom of each field.
BURL	31	TTL/ CMOS	<b>Burst lock flag.</b> When high, this output indicates that the chip's internal <i>subcarrier synthesizer is phase-aligned</i> with the current line's incoming chroma burst. The flag goes low when the internal and external phases diverge.
<b>Analog Interface</b>			
VREF	70	+1.23 V	<b>VREF input/output.</b> +1.23 Volt reference. When the internal voltage reference is used, this pin should be decoupled to AGND with a 0.1 $\mu$ F capacitor. An external +1.2 Volt reference may be connected here, overriding the internal reference source.
COMP	88	0.1 $\mu$ F	<b>Compensation capacitor.</b> Compensation for DDS D/A converter circuitry. This pin should be decoupled to VDDA with a 0.1 $\mu$ F capacitor.
RB, RT	57, 68	0.1 $\mu$ F	<b>A/D VREF decoupling.</b> Decoupling points for A/D converter voltage references. These pins should be decoupled to AGND with a 0.1 $\mu$ F capacitor.
<b>PLL Filter</b>			
DDS OUT	82		<b>Internal DDS output.</b> Analog output from the internal Direct Digital Synthesizer D/A converter, at 1/9 the PXCK frequency.
PFD IN	77		<b>Horizontal PLL input.</b> Analog input to the Phase/Frequency Detector of the horizontal phase-locked loop.
CBYP	75	1 $\mu$ F	<b>Comparator bypass.</b> Decoupling point for the internal comparator reference of the Phase/Frequency Detector. This pin should be decoupled to AGND with a 0.1 $\mu$ F capacitor.
<b>Power Supply</b>			
VDDA	49, 51, 52, 60, 64, 73, 87	+5 V	<b>Analog power supply.</b> Positive power supply to analog section. All pins must be connected.
VDD	6, 18, 26, 42, 44, 48, 92, 98, 100	+5 V	<b>Digital power supply.</b> Positive power supply to digital section. All pins must be connected.
<b>Ground</b>			
AGND	50, 55, 63, 67, 69, 72, 74, 81, 89	0.0 V	<b>Analog ground.</b> Ground for analog section. All pins must be connected.
DGND	8, 16, 27, 38, 39, 41, 46, 47, 90, 95-97	0.0 V	<b>Digital ground.</b> Ground for digital section. All pins must be connected.

## Control and Status Register Bit Functions

### Summary

Register	Function
Reg 00	97h (year of revision) read only
Reg 01	20h (part #) read only
Reg 02	72h (part #) read only
Reg 03	01h (silicon revision #) read only
Reg 04	Reserved
Reg 05	Lock flags; sync tip read only
Reg 06	Blank level read only
Reg 07	Reserved
Reg 08	Format; clock rate; freerun; clamp; reset
Reg 09	HSync lead/lag
Reg 0A	Gain; loop filter bandwidth; subpixel sync & clk position
Reg 0B	Video source select
Reg 0C	Vsync delay
Reg 0D	Sync tip set
Reg 0E	Output timing, tristate
Reg 0F	Reserved

### Details

Bit	Name	Function
<b>Reg 00 97h (year of revision)</b>		<b>Read Only</b>
<b>Reg 01 20h (part #)</b>		<b>Read Only</b>
<b>Reg 02 72h (part #)</b>		<b>Read Only</b>
<b>Reg 03 01h (silicon revision #)</b>		<b>Read Only</b>
<b>Reg 04 Reserved</b>		
<b>Reg 05 Lock Flags &amp; Sync Height</b>		<b>Read Only</b>
7	BURST_DET	Each time a high-frequency signal is detected during a video line's normal expected burst interval, this flag goes high until the next line's expected burst period. If no high-frequency signal is present during the expected burst interval, this flag goes low. With a standard color television signal input, this flag will be low during vertical field groups and, in PAL, Bruch-blanked lines. [TMC22071A bit 47.]
6	BURST LOCK	If the subcarrier loop is unlocked on the current video line, i.e., the subcarrier phase error measured during burst exceeds the lock threshold, this flag goes low until the next burst interval. If the phase error is less than the threshold, the flag is reset high. This flag is meaningful only if $\overline{\text{HLOCK}}$ is low.
5	HLOCK	During each video field, if most horizontal sync pulses arrive more than 15 pixels before or after their expected positions, this flag will go high. If most of the field's incoming horizontal syncs fall within 15 pixels of their expected positions, this flag will go low. [TMC22071A bit 56.]
4:0	ST	These bits report the each line's average sync tip level out of the A/D converter (as observed over CVBS). For a clean signal, the reported value will match the sync tip set in Reg 0D, below.

## Details (continued)

Bit	Name	Function
<b>Reg 06 Blank level</b>		<b>Read Only</b>
7:0	BP	Blank level, as measured at the low-pass-filtered A/D output during each line's color back porch. For a standard video input, its decimal value will be approximately 60 (NTSC) or 64 (PAL). [TMC22071A bits 55:48.]
<b>Reg 07 Reserved</b>		
<b>Reg 08 Standard and Clock Rate Select</b>		
7:6	V_STD	<b>Video Standard.</b> These two control bits select the incoming video standard, viz: 00 NTSC, NTSC-EIAJ (power-on default) 01 PALM (Brazil) 10 PALB,G,H,I 11 PALN (Argentina)  [With bits 5:4, these bits cover all functions of TMC22071A bits 3:1.]
5:4	CK_RATE	<b>Pixel Clock/Sample Rate.</b> Pixel (sample) rate selector, as follows: 00 12.27 MHz (power-on default; 525-line VGA) 01 13.5 MHz (D1 television rate) 10 14.75 MHz (625-line square-pixel VGA) TMC2072-1 only 11 15.0 MHz TMC2072-1 only  Note: The 12.27 MHz pixel rate is reserved for 525-line television standards (NTSC, PAL-M), whereas the 14.75 and 15.0 MHz rates are for 625-line standards (all other PAL) only. Bit combinations 0x1x and 1x00 may yield stable composite data samples, sync pulses, and pixel clock, but no useful color subcarrier information.
3	FREERUN	<b>Freerun vs. Genlock Operation.</b> LOW (power-on default): Standard genlock mode, in which the PXCK, $\overline{\text{GHSYNC}}$ , and $\overline{\text{GVSYNC}}$ lock to the incoming video's observed sync pattern. HIGH: $\overline{\text{GHSYNC}}$ is counted down from a free-running PXCK, which is unrelated to the incoming video. [TMC22071A bit 26.]
2	$\overline{\text{BPFOUT}}$	<b>Genlock Reference Signal Enable.</b> LOW (power-on default): Loop-predicted subcarrier phase and frequency data (GRS) are sent over CVBS during each horizontal sync pulse. HIGH: GRS data suppressed, such that the CVBS datastream is just the digitized incoming video signal. [TMC22071A bit 33.]
1	DC_CLAMP	HIGH (power-on default): vertically low-pass filtered digital porch clamp enabled. LOW: digital clamp disabled [TMC22071A bit 34, except that the TMC22071A clamp has no vertical filter.]
0	S_RESET	<b>Master Software Reset Control.</b> HIGH (power-on default & self-reset state): normal operation. LOW: Bringing this "one-shot" control low resets all internal state machines and registers except the microprocessor control bits themselves. The bit then sets itself high, permitting normal operation. (Because it automatically returns to the high state, this bit will always appear as a 1 when read through the microprocessor port.) [TMC22071A bit 0.]
<b>Reg 09 Lead-Lag</b>		
7:0	LEAD_LAG	<b>Hsync Lead/lag Control</b> (in one-pixel = two-PXCK increments). Power-on default = 80 Hex. To advance (delay) $\overline{\text{GHSYNC}}$ and $\overline{\text{GVSYNC}}$ relative to the video input, decrease (increase) the value. Program code 79h, with sub pixel control = 0.5 will align the $\overline{\text{GHSYNC}}$ output with the falling sync edge of the input video. [TMC22071A bits 24:17.]

## Details (continued)

Bit	Name	Function
<b>Reg 0A Gain, loop filter, subpixel adjust</b>		
7	V_GAIN	<b>Analog Gain into A/D Converter.</b> LOW (power-on default): unity gain, suitable for nominal 1-volt (sync tip to reference white) video signals. HIGH: 1.5 X gain, for over-terminated video signals with approximately 200mV sync tips. [TMC22071A bit 9.]
6	DDS_TEST	<b>Reserved</b> , test bit for DDSDAC; reset low (power-on default)
5	HFILT	<b>Horizontal Phase-Locked Loop Filter Bandwidth.</b> LOW (power-on default): narrow H loop filter to minimize jitter with clean video sources. HIGH: wide filter bandwidth, to better accommodate jittery or noisy sources.
4:0	SUBPIX	<b>Sample Clock (and Sync Signal) Subpixel Offset Timing Control.</b> Format is fractional two's complement, i.e., 0.SFFFF, where bit 4, the signed most significant bit (S), represents 1 PXCK or 1/2 pixel. Thus, the programming range is 01111 = +15/32 pixel to 10000 = -16/32 pixel. A value of 01000 will advance the sample clock and syncs by 1/4 pixel relative to the incoming video, whereas a value of 11000 will retard them the same amount. The power-on default value of 0 nominally aligns the sample clock with the center of the incoming signal's falling sync edges. [TMC22071A bits 16:12.]
<b>Reg 0B Input select</b>		
7		<b>Reserved</b> , reset low (power-on default)
6	NCOMP	<b>Reserved</b> , test bit: noise comparator disable; reset low (power-on default)
5:4	SOURCE	These two bits determine which of the three analog input lines is active, as follows:  00 VIN1 (power-on default) 01 VIN2 1X VIN3.  [TMC22071A bits 8:7.]
3	SCALE	Reset low (power-on default) to compensate burst PLL for line-by-line changes in sampling rate. Set high to disable compensation (test purpose only).
2:0	ANTEST	<b>Reserved</b> , analog circuit test bits; reset low (power-on default)
<b>Reg 0C Field and Vsync reporting</b>		
7		<b>Reserved</b> , reset low (power-on default)
6	FID FREE	LOW (power-on default): The color frame identifier (FID[1] in NTSC) toggles smoothly, but with no guaranteed relationship to the incoming color burst phase. HIGH freezes FID[1] in NTSC mode, if a two-field (odd/even only) sequence is desired.
5:3		<b>Reserved</b> , reset low (power-on default)
2	DLYRPTF	<b>Delay Field i.d. Update.</b> LOW (power-on default): FID will increment at the start of each incoming vertical sync pulse group. (NTSC lines 4 and 266.) HIGH: FID will increment at the start of the next line after the start each incoming vertical sync.
1	DLYRPT	<b>Delay GVSYNC Output.</b> LOW (power-on default): TMC2072 will generate a GVSYNC falling edge as it predicts the start of a new vertical sync series. This is recommended for laser disk or higher quality video signals, for which the chip can easily predict video field timing. HIGH: TMC2072 will generate a GVSYNC falling edge on the line after it detects the start of a vertical sync series. This is recommended for jittery input signals, if a one-line upward image displacement is acceptable.

## Details (continued)

Bit	Name	Function
0	ENAGC	<b>Re-Enable Automatic Gain Control.</b> HIGH (self-resetting one-shot): Initiates a new, self-terminating one-frame AGC sequence, independent of sync lock status. LOW (power-on default and self-reset): AGC is enabled for one frame when video sync is initially acquired, and each time sync is lost and reacquired. [TMC22071A bit 25].
<b>Reg 0D Sync Tip Set</b>		
7:4		<b>Reserved</b>
3:0	ST[3:0]	<b>Programmable Sync Tip Value.</b> Power-on default = 0. Recommended setting = 3. When the chip has achieved stable lock, this will be the average value output over CVBS during sync tips and equalization pulses. [TMC22071A bit 43:40.]
<b>Reg 0E</b>		
7	FLIPPX	LOW (power-on default): Phase of PXCK output matches that of the TMC22071A. HIGH: Phase of PXCK output is inverted, relative to that of the TMC22071A.
6	FLIPLDV	LOW (power-on default): Phase of LDV output matches that of the TMC22071A. HIGH: Phase of LDV output is inverted, relative to that of the TMC22071A.
5	XDLY	LOW (power-on default): PXCK output timing matches that of TMC22071A. HIGH: PXCK output is delayed approximately 5-10ns, to simplify interface timing in some systems.
4	VDLY	LOW (power-on default): LDV output timing matches that of TMC22071A. HIGH: LDV output is delayed approximately 5-10ns, to simplify interface timing in some systems.
3	ENVHCVBS	LOW (power-on default): Digital outputs CVBS0-7, FID(2:0) and GV/GHSYNC are tristated, to avoid bus contentions elsewhere on the system. HIGH: These pins are enabled, for normal operation.
2	FORCEZERO	LOW (power-on default): If the Hloop loses lock (Hlock\ goes high), the CVBS port will output the default subcarrier frequency and cumulative phase keyed to each GHSYNC falling edge, and the raw output of the A/D converter at all other times. In this case, since the incoming video and internal state machine are asynchronous, GRS data may appear anywhere along each digitized video line. HIGH: If the Hloop loses lock, the CVBS data port will yield only the default subcarrier phase and frequency data, and zero at all other times.
1:0		<b>Reserved, reset low (power-on default)</b>
<b>Reg 0F</b>		
7:0		<b>Reserved, reset low (power-on default)</b>

## Horizontal Timing

Horizontal line rate is determined by the V\_STD control bits. Figure 4 illustrates the horizontal blanking interval. Figure 5 completes the definition of timing parameters with vertical blanking interval detail.

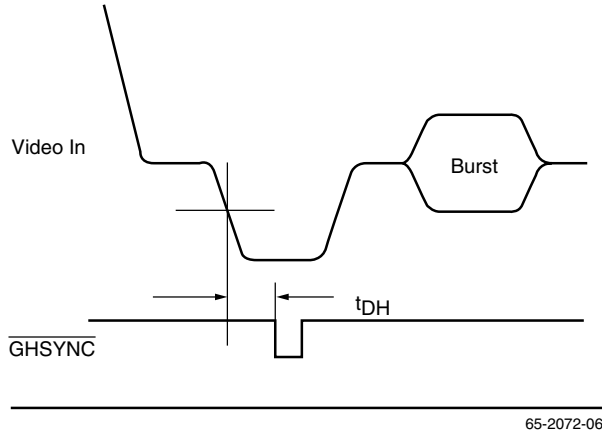

Figure 4. Horizontal Sync Timing

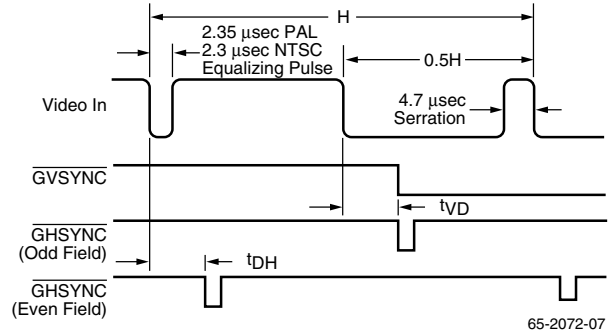

Figure 5. Vertical Sync timing

## Programming the TMC2072

Upon power-up after bringing  $\overline{\text{RESET}}$  LOW, the TMC2072 Control Register is set to default values listed previously. These default values do not necessarily render the TMC2072 operational in any specific application. Before the TMC2072 is expected to acquire input video, its Control Register must be loaded with control values specific to its use.

Table 2. TMC2072 Timing Options

Standard	Field Rate (Hz)	Line Rate (kHz)	Pixel Rate (Mpps)	PXCK Frequency (MHz)	Pixels Per Line
NTSC, PAL-M	59.94	15.734264	12.2727+	24.54+	780
NTSC-D1	59.94	15.734264	13.50	27.0	858
PAL-D1	50.00	15.625	13.50	27.0	864
PAL-VGA*	50.0	15.625	14.75	29.0	944
PAL-VGA*	50.0	15.625	15.0	30.0	960

\*TMC2072-1 only

Table 3. Control Register Example Data

Register	Value	Function
8	10h	13.5 MHz Pixel Rate
D	03h	Sync tip = 3
E	08h	Enable Outputs

Assumptions: Clean 1-volt (sync to ref white) signal on  $V_{IN1}$ . All other control registers left in power-up states.

### CVBS Bus Data Formats

The CVBS bus outputs a Genlock Reference Signal (GRS) along with the 8-bit digital composite video data. The range of output data versus video input voltage is illustrated in Figure 6 where sync tip and blanking levels are controlled by the digital backporch clamp of the TMC2072. During horizontal sync, the TMC2072 outputs field identification, subcarrier frequency, and subcarrier phase information on the CVBS bus.

Field identification is output on CVBS<sub>2-0</sub>. The LSB, CVBS<sub>0</sub>, will be LOW during odd fields and HIGH for even fields. When NTSC operation is selected, CVBS<sub>1-0</sub> count 00,01,10,11 for fields 1 through 4 respectively. When PAL operation is selected, CVBS<sub>2-0</sub> count 000,001,010, etc. to 111 for fields 1 through 8, respectively.

CVBS<sub>3</sub> indicates V-component inversion in PAL. It is HIGH for NTSC lines (burst 135°) and LOW for PAL lines (burst 225°)

Subcarrier frequency is sent out in a 24-bit binary representation in six 4-bit nibbles on CVBS<sub>3-0</sub>. Subcarrier frequency, f<sub>23-0</sub>, is that of the on-chip burst PLL.

Subcarrier phase, Φ<sub>23-0</sub>, is also sent out in a 24-bit binary representation in six 4-bit nibbles on CVBS<sub>3-0</sub>. Bit Φ<sub>23</sub> is the MSB.

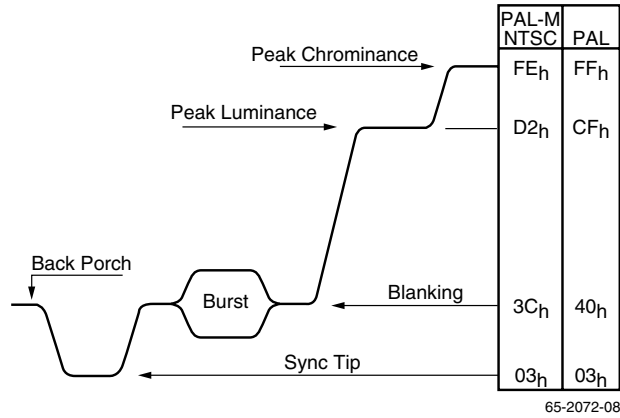

Figure 6. Output Data vs. Input Video Level

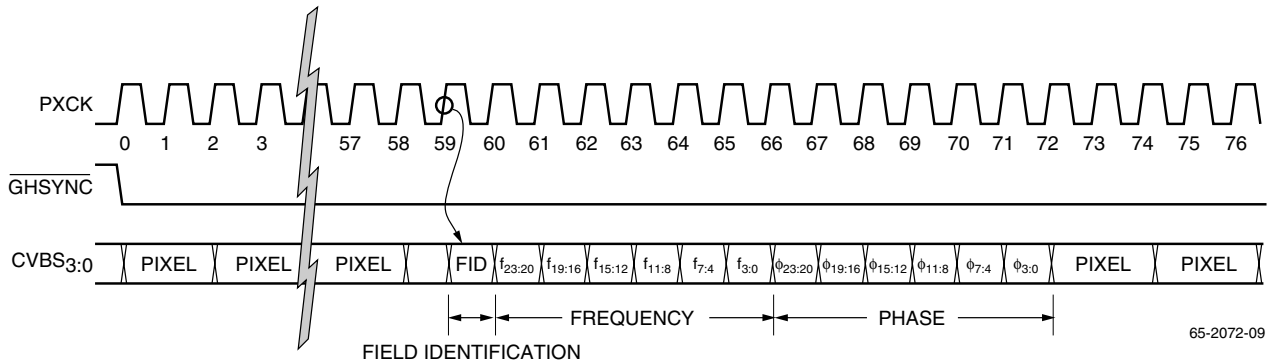

Figure 7. Genlock Reference Signal (GRS) Format

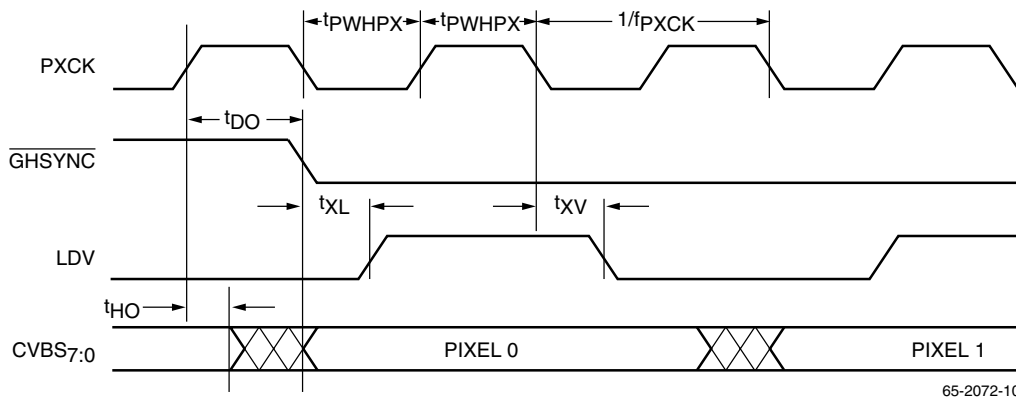

Figure 8. CVBS Bus Video Data Format

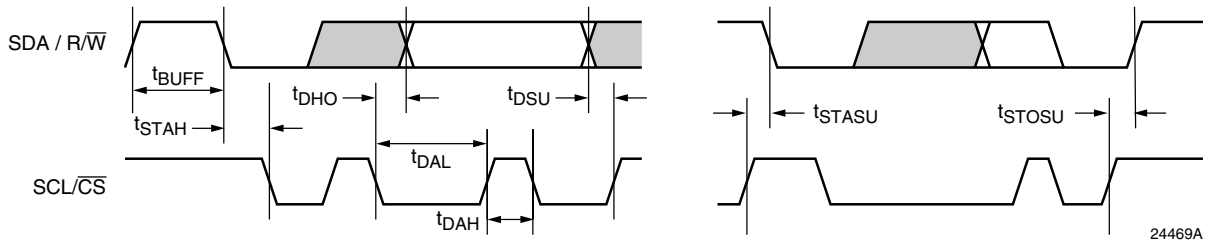

Figure 9. Serial Port Read/Write Timing

24469A

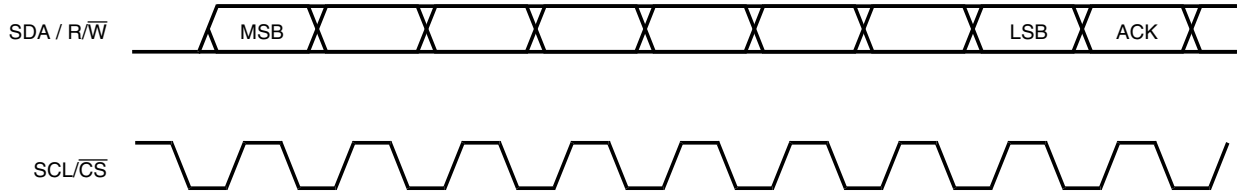

Figure 10. Serial Interface – Typical Byte Transfer

24470A

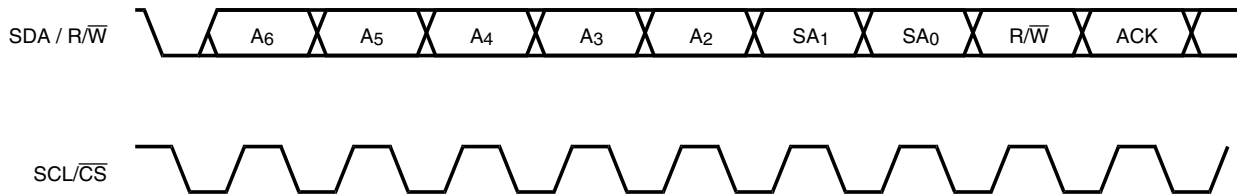

Figure 10A. Chip Address with Read/Write Bit

65-3648-05

### Equivalent Circuits

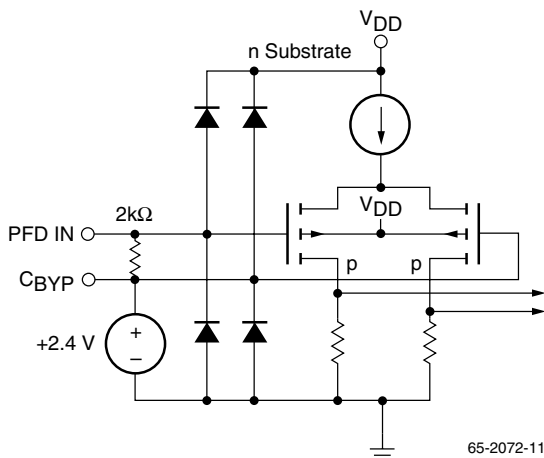

Figure 11. Equivalent PFD IN Circuit

65-2072-11

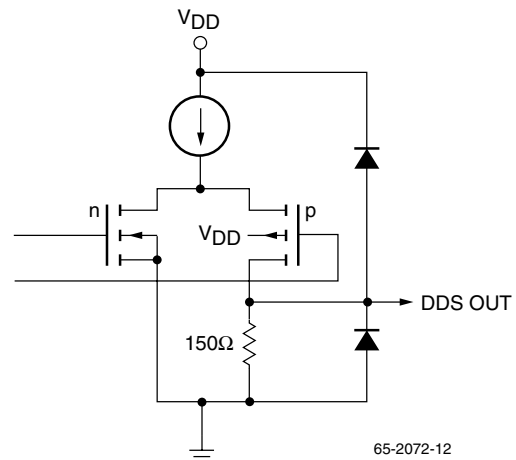

Figure 12. Equivalent DDS OUT Circuit

65-2072-12

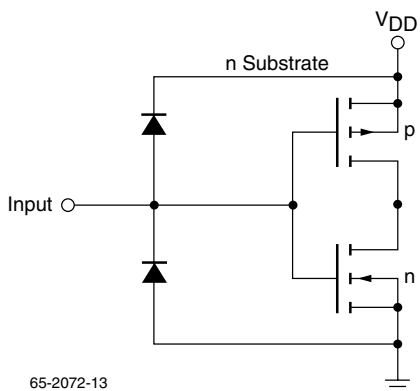

Figure 13. Equivalent Digital Input Circuit

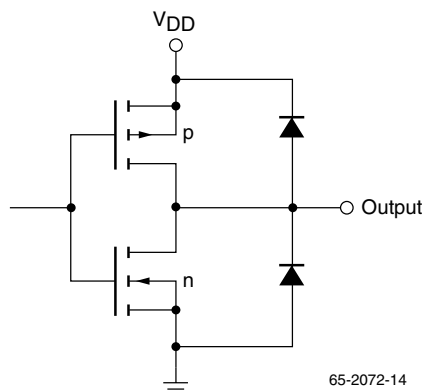

Figure 14. Equivalent Digital Output Circuit

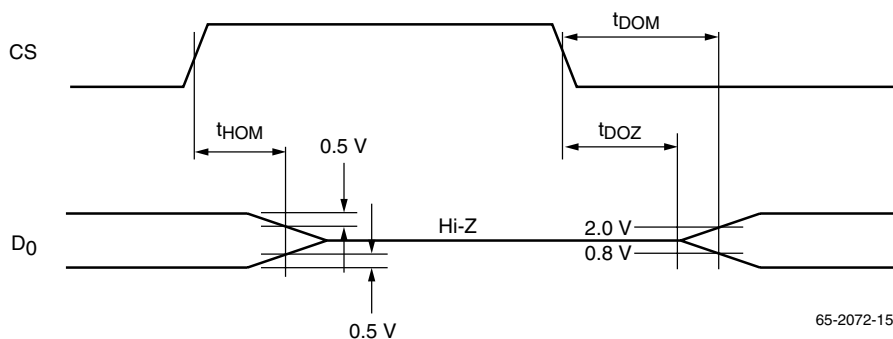

Figure 15. Transition Levels for Three-State Measurements

**Absolute Maximum Ratings** (beyond which the device may be damaged)<sup>1</sup>

Parameter	Min.	Max.	Unit
Power Supply Voltage	-0.5	7.0	V
Input Voltage	-0.5	V <sub>DD</sub> + 0.5	V
<b>Digital Outputs</b>			
Applied Voltage <sup>2</sup>	-0.5	V <sub>DD</sub> + 0.5	V
Forced Current <sup>3,4</sup>	-6.0	6.0	mA
Short Circuit Duration (single output in HIGH state to GND)		1	sec
<b>Temperature</b>			
Operating, Case	-60	130	°C
Operating, Junction		150	°C
Lead Soldering (10 seconds)		300	°C
Vapor Phase Soldering (1 minute)		220	°C
Storage	-65	150	°C

**Notes:**

1. Absolute maximum ratings are limiting values applied individually while all other parameters are within specified operating conditions. Functional operation under any of these conditions is NOT implied.
2. Applied voltage must be current limited to specified range, and measured with respect to GND.
3. Forcing voltage must be limited to specified range.
4. Current is specified as conventional current, flowing into the device.

## Operating Conditions (for standard temperature range)

Parameter		Min.	Nom.	Max.	Unit
VDD	Power Supply Voltage	4.75	5.0	5.25	V
VIH	Input Voltage, Logic HIGH				
	TTL Inputs	2.0		VDD	V
	CMOS Inputs	2/3VDD		VDD	V
VIL	Input Voltage, Logic LOW				
	TTL Inputs	DGND		0.8	V
	CMOS Inputs	DGND		1/3 VDD	V
IOH	Output Current, Logic HIGH			-2.0	mA
IOL	Output Current, Logic LOW			4.0	mA
VIN	Video Input Signal Level, Sync Tip to Peak White	0.9	1.0	1.1	V
VREF	External Reference Voltage		1.235		V
TA	Ambient Temperature, Still Air	0		70	°C
<b>Serial Microprocessor Interface</b>					
tDAL	SCL Pulse Width, LOW		1.3		µs
tDAH	SCL Pulse Width, HIGH		0.6		µs
tSTAH	SDA Start Hold Time		0.6		µs
tSTASU	SCL to SDA Setup Time (START)		0.6		µs
tSTOSU	SCL to SDA Setup Time (STOP)		0.6		ns
tBUFF	SDA Stop to SDA Start Hold Time		1.3		µs
tDSU	SDA to SCL Data Setup Time		300		ns
tDHO	SCL to SDA Hold Time		300		ns

### Note:

1. Timing reference points are at the 50% level.

## Electrical Characteristics (for standard temperature range)

Parameter		Conditions	Min.	Typ.	Max.	Unit
IDD	Power Supply Current <sup>1</sup>	Total Current VDD = Max, fPXCK = 30MHz		190	230	mA
IREF	Reference Input Current	VREF = +1.235V			100	µA
IiH	Input Current, Logic HIGH	VDD = Max, VIN = 4.0V			±10	µA
IiL	Input Current, Logic LOW	VDD = Max, VIN = 0.4V			±10	µA
VOH	Output Voltage, Logic HIGH	IOH = -2.0 mA	2.4			V
VOL	Output Voltage, Logic LOW	IOL = 4.0 mA			0.4	V
IOZH	Hi-Z Output Leakage current, HIGH	VDD = Max, VIN = VDD			±10	µA
IOZL	Hi-Z Output Leakage current, LOW	VDD = Max, VIN = GND			±10	µA
CI	Digital Input Capacitance	TA = 25°C, f = 1 Mhz		4	15	pF
CO	Digital Output Capacitance	TA = 25°C, f = 1 Mhz		10		pF
CV	Input Capacitance, VIN1-3	TA = 25°C, f = 3.58 Mhz			15	pF
RV	Input Resistance, VIN1-3		50			kΩ

### Note:

1. Typical IDD with VDD = +5.0 Volts and TA = 25°C, Maximum IDD with VDD = +5.25 Volts and TA = 0°C.

### Switching Characteristics (for standard temperature range)

Parameter	Conditions	Min.	Typ.	Max.	Unit
t <sub>DO</sub>	Output Delay Time			15	ns
t <sub>HO</sub>	Output Hold Time			8	ns
f <sub>PCK</sub>	Pixel Rate			15.3	MHz
f <sub>PXCK</sub>	Master Clock Rate			27.4 30.6	MHz
t <sub>PWHPX</sub>	PXCK Pulse Width, LOW	27 MHz			ns
t <sub>PWHPX</sub>	PXCK Pulse Width, HIGH	27 MHz			ns
t <sub>DH</sub>	Horizontal Sync to $\overline{\text{GHSYNC}}$	For low-jitter video source, Lead - Lag = 80h		14	pxck
t <sub>VD</sub>	Vertical Sync to $\overline{\text{GVSYNC}}$	For low-jitter video source, Lead - Lag = 80h		14	pxck
t <sub>XL</sub>	PXCK LOW to LDV HIGH	FLIPPX = 0, FLIPLDV = 0		10	ns
t <sub>XV</sub>	PXCK LOW to LDV LOW	XDLY = 0, VDLY = 0		6	ns

### System Performance Characterlctics

Parameter	Conditions	Min.	Typ.	Max.	Unit
ESCH	Sync time-base variation <sup>1</sup>			±3	ns
ESCP	Subcarrier Phase Error <sup>1</sup>			±2	degrees
t <sub>AL</sub>	Line-lock Acquisition Time			2	frames
VXT	Channel-to-Channel Crosstalk @ 3.58 Mhz			-35	dB

**Note:**

1. NTSC/PAL compliant black burst at nominal input level ±10%, frequencies nominal ±10 ppm.

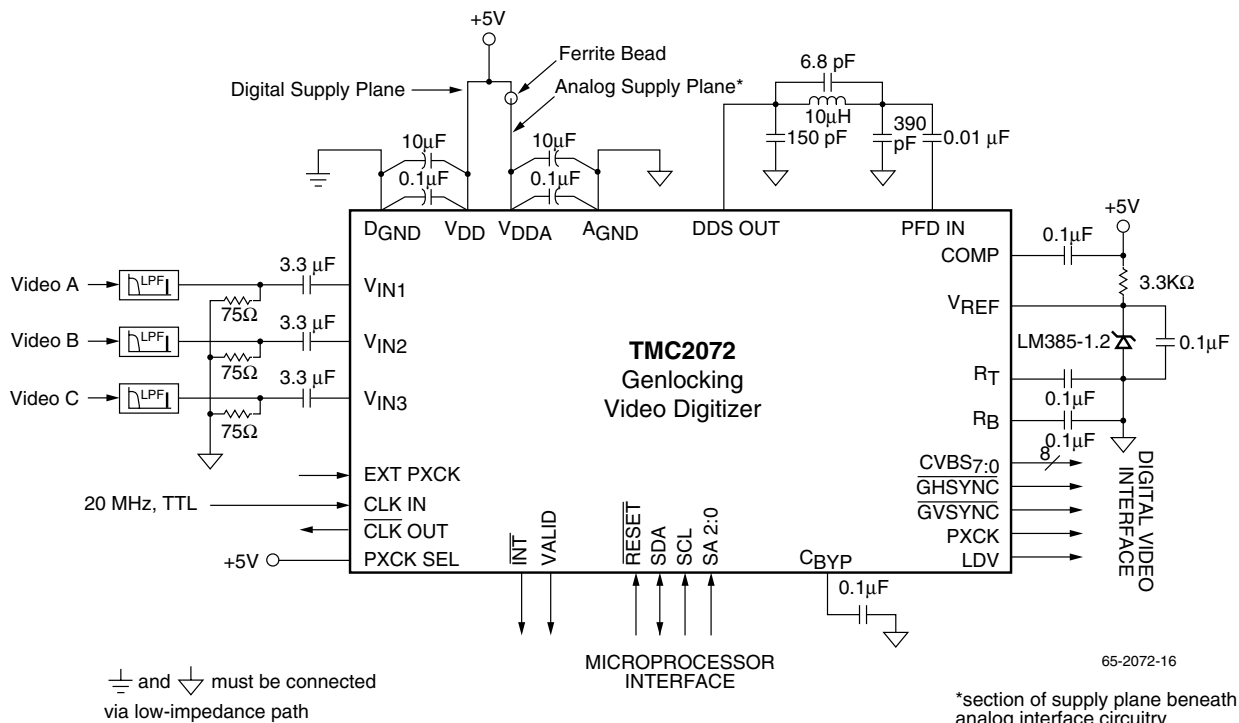

Figure 16. Typical Interface Circuit

## Application Notes

The TMC2072 is a complex mixed-signal VLSI circuit. It produces CMOS digital signals at clock rates of up to 15 MHz while processing analog video inputs with a resolution of less than a few millivolts. To maximize performance it is important to provide an electrically quiet operating environment. The circuit shown in Figure 16 provides an optional external 1.2V reference to the VREF input of the TMC2072. The internal VREF source is adequate for most applications.

### Filtering

Inexpensive low-pass anti-aliasing filters are shown in Figures 17 and 18. These filters would normally be inserted in the video signal path just before the 75Ω terminating resistor and AC-coupling capacitor for each of the three video inputs, VIN1-3. The filter of Figure 17 exhibits a 5th-order Chebyshev response with -3dB bandwidth of 6.7MHz and a group delay of 140 nanoseconds at 5MHz. The filter of Figure 18 has been equalized for group delay in the video signal band. Its -3dB passband is 5.5MHz while the group delay is constant at 220 nanoseconds through the DC to 5MHz frequency band.

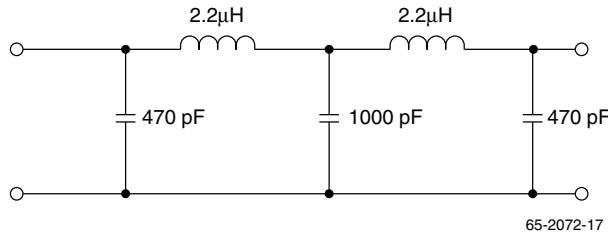

Figure 17. Simple Anti-aliasing Filter

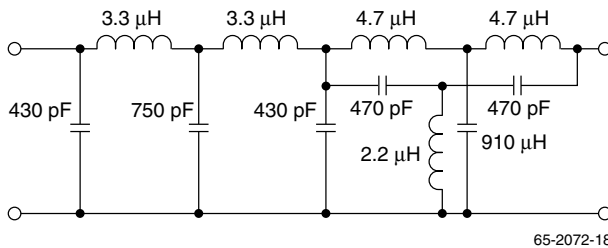

Figure 18. Group Delay Equalizer Filter

### Using a 20 MHz Crystal

In systems where a 20 MHz clock is not available, a crystal may be used to generate the clock to the TMC2072. The crystal must be a 20 MHz “fundamental” type, not overtone. Specific crystal characteristics are listed in Table 4 and the connections are shown in Figure 19.

Table 4. Crystal Parameters

Parameter	Value
Fundamental frequency	20 MHz
Tolerance	±30 ppm @ 25°C
Stability	±50 ppm, 0°C to 70°C
Load Capacitance	20 pF
Shunt Capacitance	7 pF Max.
ESR	50 Ω, Max.

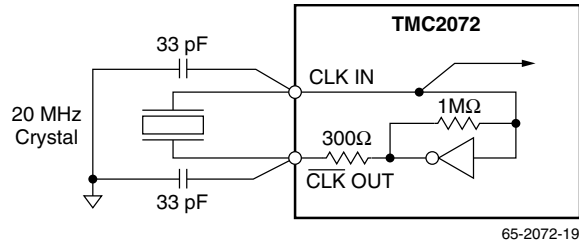

Figure 19. Direct Crystal Connections

### Grounding

The TMC2072 has separate analog and digital circuits. To minimize digital crosstalk into the analog signals, the power supplies and ground connections are provided over separate pins (VDD and VDDA are digital and analog power supply pins; DGND and AGND are digital and analog ground pins). In general, the best results are obtained by tying all grounds to a solid, low-impedance ground plane. Power supply pins should be individually decoupled at the pin. Power supply noise isolation should be provided between analog and digital supplies via a ferrite bead inductor on the analog lead. Ultimately all +5 Volt power to the TMC2072 should come from the same power source.

Another approach calls for separating analog and digital ground. While some systems may benefit from this strategy, analog and digital grounds must be kept within 0.1V of each other at all times.

### Unused Video Inputs

The TMC2072’s three video inputs (VIN1, VIN2, and VIN3) are high impedance, diode-protected against moderate electrostatic discharge, and DC biased to approximately 1.9V. We recommend tying any unused inputs to ground or to VDD through a 1 MΩ resistor or a capacitor. Unused inputs may also be left open without damaging the part. If grounded directly, a video input port will source less than 1mA when selected.

### Interface to the TMC22x5y Decoder

The TMC22x5y Digital Video Decoders have been designed to directly interface to the TMC2072 Digital Video Genlock. The TMC2072 is the source for TMC22x9x input signals CVBS7-0, GHSYNC, GVSYNC, LDV, and PXCK as shown in Figure 20. These signals directly connect to the

TMC22x5y. The serial microprocessor interfaces for TMC22x5y and TMC2072 are identical. The SDA and SCL bus signals from the host microprocessor are shared by the TMC22x5y and TMC2072. Only SA[2:0], VALID, and INT signals are separate from the microprocessor bus.

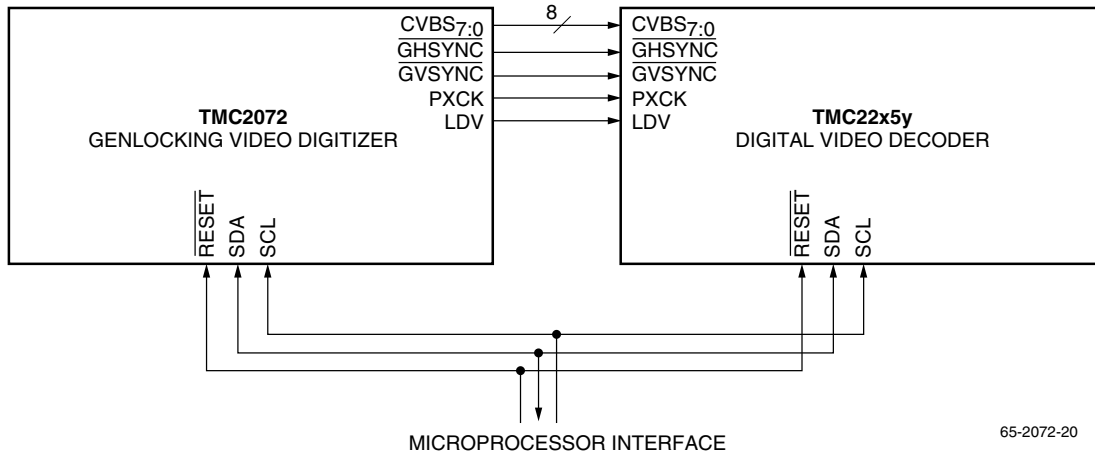

Figure 20. TMC22x5y Interface Circuit

### Printed Circuit Board Layout

Designing with high-performance mixed-signal circuits demands printed circuits with ground planes. Wire-wrap is not an option. Overall system performance is strongly influenced by the board layout. Capacitive coupling from digital to analog circuits may result in poor picture quality. Consider the following suggestions when doing the layout:

1. Keep the critical analog traces (COMP, VREF, RT, RB, DDS OUT, PFD IN, CBYP, and VIN1-3) as short as possible and as far as possible from all digital signals. The TMC2072 should be located near the board edge, close to the analog output connectors.
2. The digital power plane for the TMC2072 should be that which supplies the rest of the digital circuitry. A single power plane should be used for all of the VDD pins. If the analog power supply for the TMC2072 is the same as that of the system's digital circuitry, power to the TMC2072 VDDA pins should be decoupled with ferrite beads and 0.1 μF capacitors to reduce noise.
3. The ground plane should be solid, not cross-hatched. Connections to the ground plane should have very short leads.

4. Decoupling capacitors should be applied liberally to VDD pins. Remember that not all power supply pins are created equal. They typically supply adjacent circuits on the device, which generate varying amounts of noise. For best results, use 0.1 μF capacitors in parallel with 10 μF capacitors. Lead lengths should be minimized. Ceramic chip capacitors are the best choice.
5. If the digital power supply has a dedicated power plane layer, it should not overlap the TMC2072, the voltage reference or the analog outputs. Capacitive coupling of digital power supply noise from this layer to the TMC2072 and its related analog circuitry can degrade performance.
6. CLK should be handled carefully. Jitter and noise on this clock or its ground reference may degrade performance. Terminate the clock line carefully to eliminate overshoot and ringing.

### Related Products

- TMC22x9x Digital Video Encoders
- TMC2242/TMC2243/TMC2246 Video Filters
- TMC2081 Digital Video Mixer
- TMC22x5y Digital Decoders
- TMC2302 Image Manipulation Sequencer

# Mechanical Dimensions

## 100 Lead MQFP Package – 3.2mm Footprint

Symbol	Inches		Millimeters		Notes
	Min.	Max.	Min.	Max.	
A	—	.134	—	3.40	
A1	.010	—	.25	—	
A2	.100	.120	2.55	3.05	
B	.008	.015	.22	.38	3, 5
C	.005	.009	.13	.23	5
D	.904	.923	22.95	23.45	
D1	.783	.791	19.90	20.10	
E	.667	.687	16.95	17.45	
E1	.547	.555	13.90	14.10	
e	.0256 BSC		.65 BSC		
L	.028	.040	.73	1.03	4
N	100		100		
ND	30		30		
NE	20		20		
$\alpha$	0°	7°	0°	7°	
ccc	—	.004	—	.12	

**Notes:**

1. All dimensions and tolerances conform to ANSI Y14.5M-1982.
2. Controlling dimension is millimeters.
3. Dimension "B" does not include dambar protrusion. Allowable dambar protrusion shall be .08mm (.003in.) maximum in excess of the "B" dimension. Dambar cannot be located on the lower radius or the foot.
4. "L" is the length of terminal for soldering to a substrate.
5. "B" & "C" includes lead finish thickness.

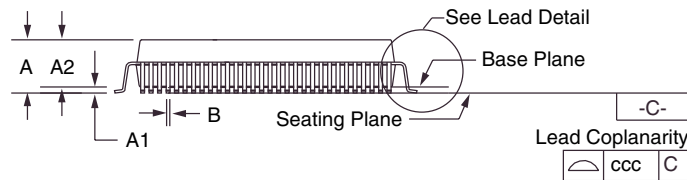
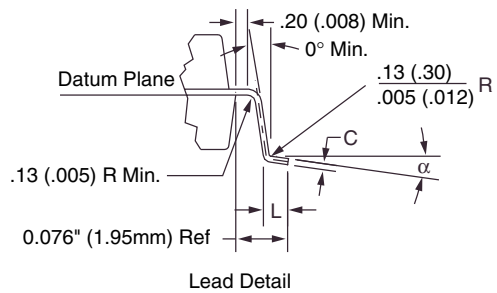
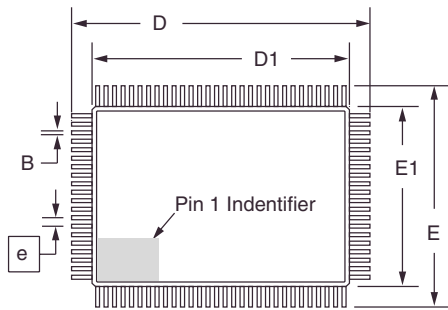

## Ordering Information

Product Number	Temperature Range	Screening	Package	Package Marking
TMC2072KHC	T <sub>A</sub> = 0°C to 70°C	Commercial	100-Lead MQFP	2072KHC

For additional information regarding our products, please visit the CADEKA at: [cadeka.com](http://cadeka.com)

**CADEKA Headquarters** Loveland, Colorado

T: 970.663.5452

T: 877.663.5415 (toll free)

CADEKA, the CADEKA logo design, and COMLINEAR and the COMLINEAR logo design, are trademarks or registered trademarks of CADEKA Microcircuits LLC. All other brand and product names may be trademarks of their respective companies.

CADEKA reserves the right to make changes to any products and services herein at any time without notice. CADEKA does not assume any responsibility or liability arising out of the application or use of any product or service described herein, except as expressly agreed to in writing by CADEKA; nor does the purchase, lease, or use of a product or service from CADEKA convey a license under any patent rights, copyrights, trademark rights, or any other of the intellectual property rights of CADEKA or of third parties.

Copyright ©2001 by CADEKA Microcircuits LLC. All rights reserved.

